

GSMO

16mm

CAMERA SYSTEM

OPERATION & MAINTENANCE MANUAL



CINEMA

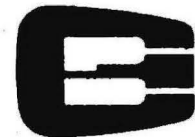

*Technology In The
Service Of Creativity*

products
CORPORATION

2037 Granville Avenue, Los Angeles, California 90025
Telephone: (213) 478-0711 • (213) 477-1971 • Teleg: 69-1339

NOVEMBER 1980

TABLE OF CONTENTS

LIST OF ILLUSTRATIONS	ii
INTRODUCTION	iii
SECTION 1 – DESCRIPTION	
General	1-1
Specifications	1-1
Camera Head	1-2
Control Panel	1-4
Switch Panel	1-4
Reflex Viewfinder	1-5
Viewing Screen	1-5
Bottom of Camera Body	1-6
Side Cover	1-6
Camera Drive	1-7
Aperture Plate and Film Transport	1-7
Lens Mount	1-8
Magazines	1-8
Power Supplies	1-9
NC-4 Battery Pack	1-9
NCC-6 Battery Charger	1-9
MBC-6 Multiple Battery Charger	1-10
Remote-Operation Battery Cable	1-10
Battery Charger Cable	1-10
Use of Accessory Connector	1-11
Remote RUN/STOP Control	1-11
Connecting Pilotone/Autoslate to Recorder	1-11
Pilotone/Autoslate Sequence	1-12
Fuses	1-12
SECTION 2 – OPERATION	
Introduction	2-1
Receiving the Camera	2-1
Camera Checkout	2-1
Loading Magazines	2-1
Removal of Magazines	2-5
Installation of Lenses	2-5
Important Features to Check Before Filming	2-5
SECTION 3 – CAMERA ACCESSORIES AND OPTIONS	
Orientable Viewfinder	3-1
Extension Tube Assembly	3-2
Semiautomatic Exposure Control	3-3
Fully Automatic Exposure Control	3-4
J-5 Zoom Control System	3-4
Handgrips and Shoulder Pod/Handgrip	3-7
Carrying Case	3-8
Steadicam	3-9

TABLE OF CONTENTS (Contd.)

SECTION 4 – FUNCTIONAL DESCRIPTION

Motor Drive System	4-1
Reference Oscillator	4-1
Pilotone, Clap, Bloop Circuit	4-3
Phase Comparator	4-3
Pulsewidth Modulator	4-4
Overload Shutdown	4-4
Control Logic	4-4
Acceleration and Reset	4-5
Power Supply	4-5
Semiautomatic and Fully Automatic Exposure Control Systems	4-5
System Description	4-5
Assembly Description	4-6
Theory of Operation	4-6

SECTION 5 – MAINTENANCE

General	5-1
Cleaning	5-1
Lubrication	5-1
Electronic Adjustments	5-1
Automatic Exposure Control	5-1

SECTION 6 – ILLUSTRATED PARTS BREAKDOWN

General	6-1
---------------	-----

LIST OF ILLUSTRATIONS

Figure No.:		Page
1-1	Typical GSMO Camera System	1-1
1-2	Camera Body	1-3
1-3	Control Panel	1-4
1-4	Switch Panel	1-4
1-5	Reflex Viewfinder	1-5
1-6	Viewing Screen	1-5
1-7	Bottom of Camera	1-6
1-8	Side Cover	1-6
1-9	Camera Drive	1-7
1-10	Film Transport	1-7
1-11	Lens Mount	1-8
1-12	400-Foot Magazine	1-8
1-13	Battery Pack	1-9
1-14	Battery Charger	1-9
1-15	Multiple Battery Charger	1-10
1-16	Battery Charger Cable	1-10
1-17	Remote-Operation Battery Cable	1-10
1-18	Remote RUN/STOP Switch	1-11
1-19	Control of Tape Recorder	1-11
1-20	Pilotone/Autoslate Sequence	1-12
2-1	Film Cutter	2-1
2-2	Threading Film on Supply Side of Magazine	2-2
2-3	Threading Film on Takeup Side of Magazine	2-3
2-4	Film Projects Through Gate	2-4
2-5	Film Pushed Up Properly in Gate	2-4
3-1	Orientable Viewfinder	3-1
3-2	Extension Tube in Use on Tripod-Mounted Camera	3-2
3-3	Exposure System Weighting Diagram	3-3
3-4	J-5 Zoom Control	3-5
3-5	J-5 Zoom Control, Electrical Schematic Diagram	3-6
3-6	Shoulder Pod With J-5 Control Grip	3-7
3-7	Compact Handgrip	3-8
3-8	Extension Handgrip	3-8
3-9	Fitted Carrying Case	3-8
3-10	Steadicam	3-9
3-11	Steadicam	3-9
4-1	GSMO Camera Electronic Block Diagram	4-1
4-2	Reference Oscillator Waveforms for 24 FPS	4-2
4-3	Pilot/Slate Sequence	4-2
4-4	Reference Frequency for Phase Discriminator	4-3
4-5	Phase-Lock Test Point	4-3
4-6	Tachometer Signal	4-4
4-7	Motor Command From Phase Discriminator	4-4
4-8	Pulsewidth Modulator Output	4-5
4-9	Automatic Exposure Control, Schematic Diagram	4-7
4-10	GSMO Camera, Schematic Diagram	4-9

LIST OF ILLUSTRATIONS (Contd.)

Figure No.		Page
6-1	GSMO Camera Assembly	6-1
6-2	Camera Assembly	6-2
6-3	Front Cover Assembly	6-5
6-4	Side Cover Assembly	6-6
6-5	Sprocket Drive Assembly	6-7
6-6	Iris Control Motor Z79-0498	6-8
6-7	79-370 and 79-370-1 Exposure Control Kits	6-10
6-8	Automatic Exposure Control Main Circuit Board Assembly Z79-0490	6-12
6-9	Automatic Exposure Control Preampfier Circuit Board Assembly Z79-0373	6-14
6-10	Automatic Exposure Control Preampfier Circuit Board Subassembly Z79-0467	6-15
6-11	Display Board Assembly Z79-0372 (Non-AEC Cameras Only)	6-17
6-12	Wiring Harness Assembly Z79-0322	6-18
6-13	Drive Amplifier Assembly Z79-0329	6-20
6-14	Main Control Board Assembly 79-0345	6-22
6-15	Control Printed Circuit Board Assembly Z79-0326	6-23
6-15A	Tach Assembly Z79-0363 (Hard-Wired to Z79-0326)	6-24
6-16	Counter Printed Circuit Board Assembly	6-26
6-17	400-Foot Magazine Assembly	6-27
6-18	Magazine Mid-Rib Assembly	6-29
6-19	Magazine Clutch and Sprocket Assembly	6-31
6-20	Magazine Supply Door Assembly	6-33
6-21	Magazine Film Gate Assembly	6-34

GSMO

16mm Camera System

OPERATION & MAINTENANCE MANUAL

INTRODUCTION

The GSMO Operation & Maintenance Manual is designed for GSMO camera operators and repair personnel. It provides complete descriptions of all GSMO camera models and accessories. The periodic adjustment and maintenance procedures described in this manual are relatively simple and easy to carry out, even under field conditions. For more complex servicing, see your authorized GSMO service center, or contact the Service Department at the factory.

Authorized Service Centers

Authorized GSMO service centers are located throughout the U.S.A. and abroad. These service centers are well stocked with critical replacement parts, and are staffed by factory-trained technicians fully qualified to service all GSMO camera models. Warranty-covered repairs should be made only through authorized GSMO service centers. Contact Cinema Products' Sales Department for an up-to-date listing of authorized service centers.

Maintenance Training Seminars

Cinema Products conducts periodic GSMO Maintenance Training Seminars which are usually held at the factory in Los Angeles. The seminar/workshops, conducted by Cinema Products factory personnel, provide in-depth information and demonstrations on the care and maintenance of GSMO camera systems, with emphasis on preventive care and effective troubleshooting in the field. We recommend that all GSMO camera operators (and maintenance technicians who service GSMO cameras) attend these seminar/workshops. Contact the GSMO Maintenance Training Seminar Coordinator for application forms and detailed information on the next scheduled seminar.

Something to remember!

If you have any further questions concerning the operation and maintenance of your GSMO camera, do not hesitate to call the factory Service Department directly. We'll do our best to help you.

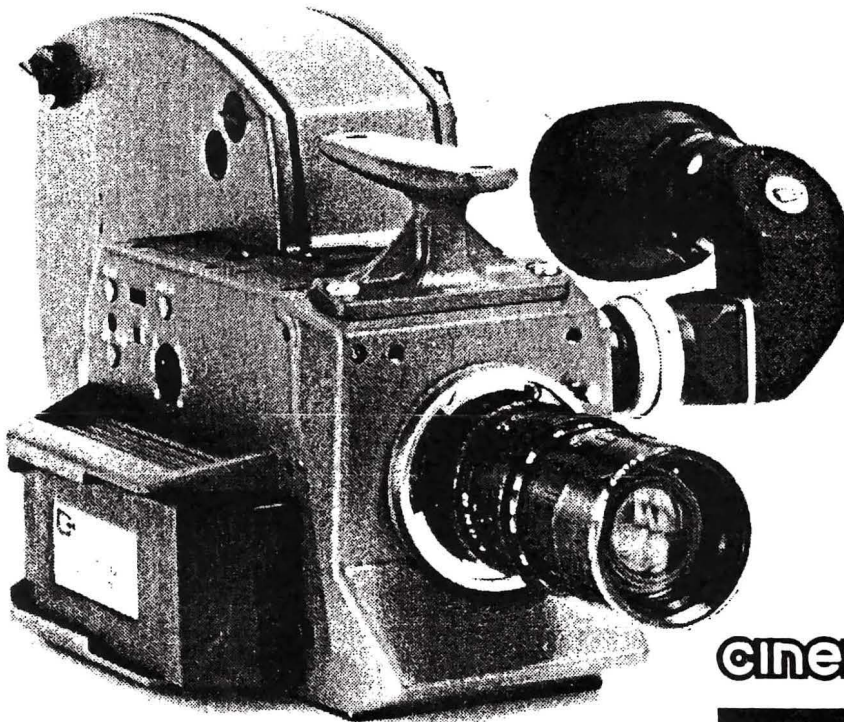

cinema  **products**
CORPORATION

Technology In The Service Of Creativity

2037 Granville Avenue, Los Angeles, California 90025
Telephone: (213) 478-0711 • (213) 477-1971 • Telex: 69-1339

SECTION 1 – DESCRIPTION

GENERAL

Cinema Products' GSMO (figure 1-1) is an ultrasilent, ultralightweight and extremely compact professional 16mm reflex motion picture camera system.

The GSMO features a 180-degree shutter, quick-change cassette-type coaxial magazine, and a full range of options and accessories. Designed for ease of operation and simple maintenance, the rugged and dependable GSMO is an ideal double-system sound production camera for all phases of 16mm cinematography.



Figure 1-1. Typical
GSMO Camera System

SPECIFICATIONS

Film Size:	16mm single or double perforated, B wind, core load or daylight load.
Film Capacity:	Quick-change, cassette-type coaxial magazines designed to accept: 30m (100') – daylight load 120m (400') – core load or daylight load
Rotating Mirror Shutter:	Single-blade, full-speed belt-driven mirror shutter set at 45-degree angle; stops automatically in viewing position.
Shutter Opening:	180 degrees
Shutter Speed:	1/48 second @ 24 fps (1/50 second @ 25 fps)
Aperture Opening:	7.46mm x 10.41mm (0.294" x 0.410")
Frame Line Accuracy:	±0.05 mm (0.002 in.)

Picture Steadiness:	± 0.0127 mm (0.0005 in.)
Viewfinder (standard):	Positive lock, 12X magnification. Provides greater than full-field viewing through fiber optics viewing screen. (Orientable viewfinder system optional.)
Warning Indicators in Viewfinder:	When illuminated, "S" indicates camera speed is not at preselected speed, or "out of sync." "B" indicates low battery.
Lens Mount:	CP bayonet mount, with a positive-locking ring. Accepts any reflex-type lens that fits on any of the existing Arriflex and Eclair cameras (with proper CP mount adapter).
Dimensions:	GSMO camera with 30m (100') magazine: 12.9 cm wide x 11.8 cm high x 21.3 cm long (5.06" x 4.63" x 8.4") GSMO camera with 120m (400') magazine: 12.9 cm wide x 18.3 cm high x 30.8 cm long (5.06" x 7.18" x 12.12")
Weights:	GSMO camera head only, with CP standard 12X viewfinder and NC-4 battery pack, less lens: 2.5kg (5 lbs 7 oz) Magazine weights: 30m (100') magazine: 0.9kg (2 lbs) 120m (400') magazine: 2.3kg (5 lbs)
Power Supply:	The GSMO is powered by the standard CP NC-4 nicad plug-in battery pack, which can drive 500 meters (up to 1600') of film through the camera on one charge.
Tripod Sockets:	1/4"-20 and 3/8"-16 tripod mount sockets.
Digital Footage Counter:	Reads in feet (full feet and tenths of feet) or meters (full meters and tenths of meters) as desired.
Sync-Sound Speed:	Crystal-controlled 24 fps or 25 fps.
Camera Speed Range:	Crystal-controlled step-variable speeds of 12, 16, 24, 25, 32, 48, and 64 fps.
Speed Accuracy:	± 30 ppm over a temperature range of -18° to 60°C (0 to 140°F) for all crystal-controlled step-variable speeds from 12 to 64 fps.
Sound Level:	30 dB maximum measured at 1m (3') from film plane on the weighted A scale.

CAMERA HEAD (Fig. 1-2)

The GSMO camera head is an assembly consisting of the body (1), side cover (2) with battery mount (3), and control panel (8) film transport movement (10), reflex viewfinder (4), lens mount (5) and cavity cap (6), carrying handle (7), switch panel (9), tripod sockets (11), magazine lock (12), release latch (13), battery release (14), and fuse (15).

Cameras with serial number 116 and up may be equipped with either semiautomatic or fully automatic exposure control. Cameras with semiautomatic exposure control display a t-stop correction on the viewfinder; those with fully automatic exposure control also include an electronically operated motor which positions the iris to the proper t-stop.

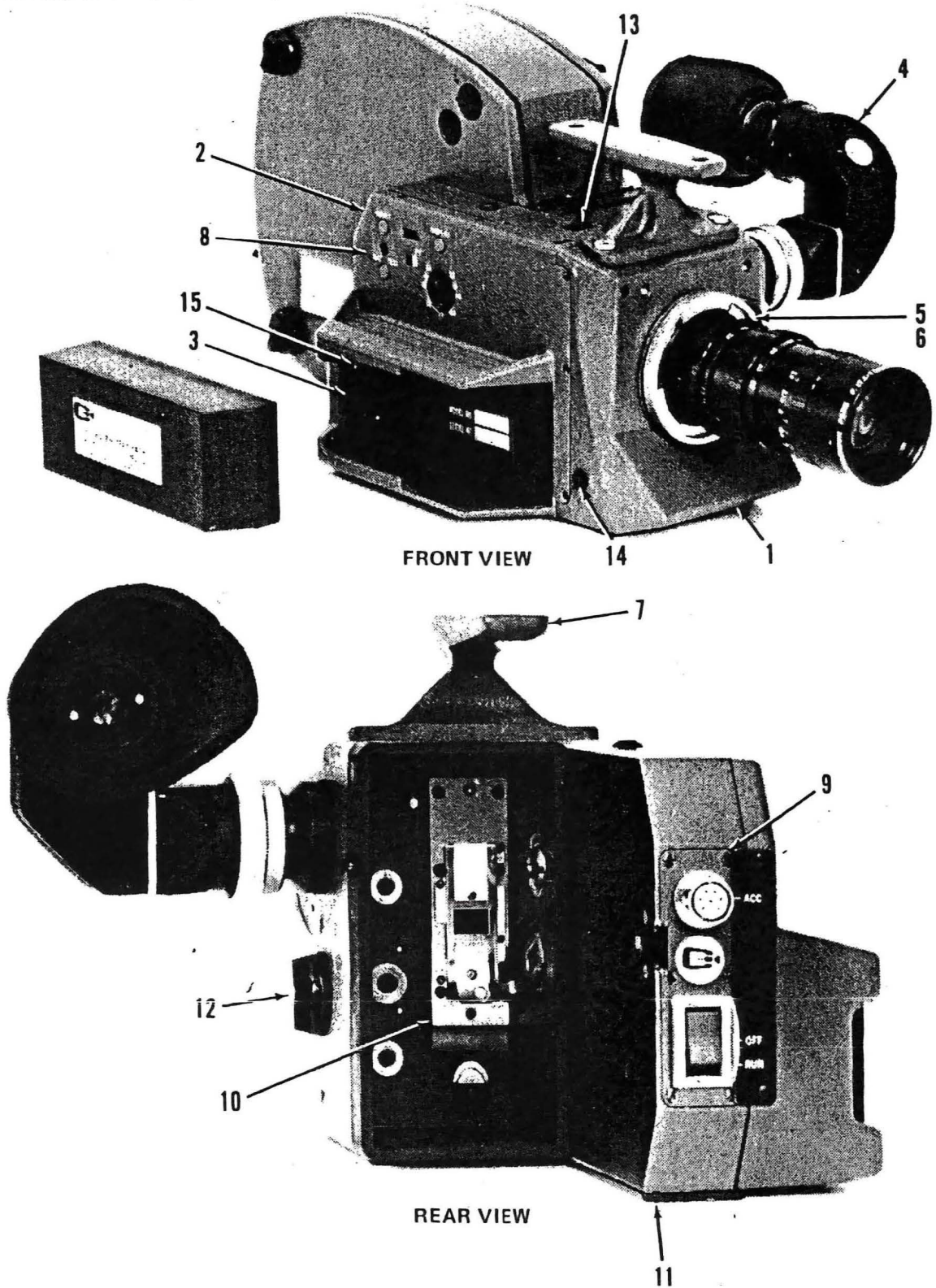

Figure 1-2. Camera Body

CONTROL PANEL (Fig. 1-3)

The control panel contains operating controls and indicators as follows:

- RESET switch:** When pressed simultaneously with display switch, resets footage counter to zero. Footage readout must be visible.
- Digital footage counter:** Displays film used since last reset in feet or meters, depending on position of M/FT switch.
- DISPLAY switch:** When pressed, lights digital footage counter.
- BAT TEST switch and indicator:** When pressed, lights indicator lamp if battery is still in usable condition.
- M/FT switch:** Selects units for display on footage counter: whole feet or meters and tenths.
NOTE: Set to desired units, then press RESET switch. Counter will not convert from feet to meters, or vice versa.
- Speed selector switch:** Selects camera speed in steps of 12, 16, 24, 25, 32, 48, or 64 frames per second.

Figure 1-3. Control Panel

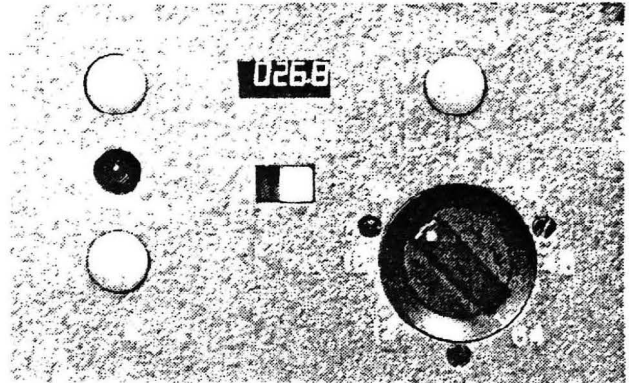

SWITCH PANEL (Fig. 1-4)

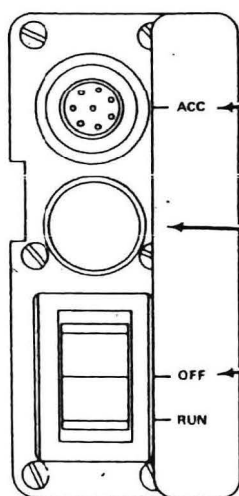

The switch panel contains the following:

- ACCY (accessory) connector:** Permits interconnection to remove camera start/stop, speed control, or recorder pilotone circuit.
- FILM SPEED selector:** Used to set film speed ASA/DIN number into cameras with semi- or fully automatic exposure control (page 3-3).
- RUN switch:** On cameras with exposure control, this is a three-position switch: AEC ON/OFF/RUN. In AEC ON or RUN position, t-stop correction is displayed on viewfinder.

Figure 1-4. Switch Panel

REFLEX VIEWFINDER (Fig. 1-5)

The standard reflex viewfinder includes an eyecup (1) which is located one inch back of the film plane. The eyecup is equipped with a backlight shutter (dowser) open/close ring control (2). The diopter adjustment (± 5 diopters) is accomplished by loosening the thumbscrew (3) and turning the adjustment barrel (4) until the frame lines on the fiber optics viewing screen (focusing plate) are sharp. Retighten the thumbscrew to prevent the setting from being changed. The viewfinder also incorporates a locking (5) and pivot (6).

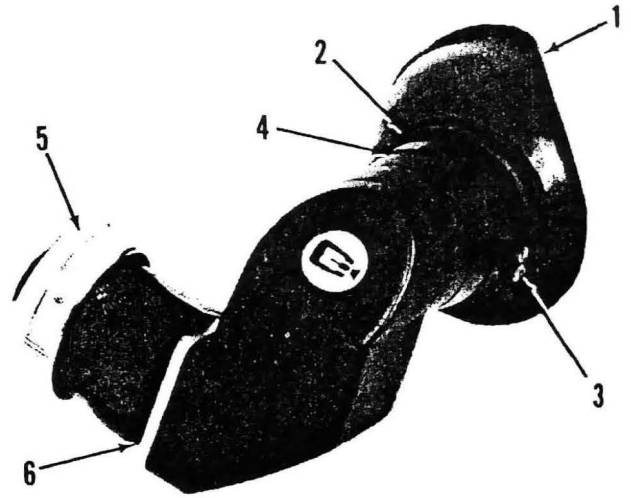

Figure 1-5. Reflex Viewfinder

VIEWING SCREEN (Fig. 1-6)

The image being viewed through the lens is observed on the viewing screen of the reflex viewfinder. Also visible in the reflex viewfinder are the frame markings plated onto the fiber optics viewing screen showing 16mm projector aperture (1) and TV safe-action area (2) plus markings for 35mm blowup (1.85:1) (1.66:1 optional) (3). The information display utilizing light-emitting diodes (LEDs) is also visible across the top of the viewing screen. Its elements are:

S = Out-of-sync warning which lights up when the camera is running "out of sync" (under or over speed)-that is, other than the frame rate selected on the control panel.

NOTE: When the camera is first started, the out-of-sync warning light goes on momentarily until the camera is up to speed. Similarly, when the camera is turned off, the out-of-sync warning light also goes on momentarily. When changing speeds, light will appear momentarily.

B = Low battery warning indicating enough battery charge remains to finish a short take, but the battery must be changed (or recharged) before a new long take is attempted.

-1 -1/2 0 +1/2 +1 + = Exposure indicators which function when the camera is equipped with either semiautomatic or fully automatic exposure control. The center display is a zero, which indicates correct exposure. To the right are +1/2, +1, and + and to the left are -1/2, -1, and -. These are half-stop increments, + and - being out-of-range indicators (i.e., + indicates 1 1/2 stops or more overexposed). Zero and a +1/2 or -1/2 on at the same time indicates 1/8 stop off of "null." See page 3-3 for more details.

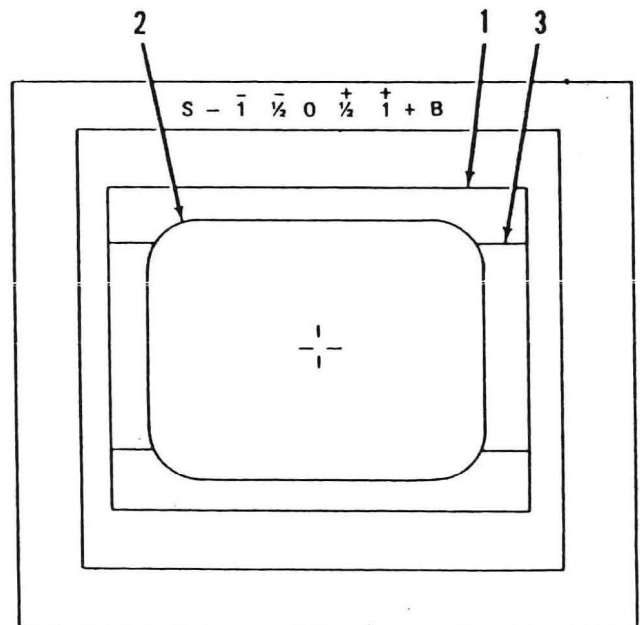

Figure 1-6. Viewing Screen

BOTTOM OF CAMERA BODY (Fig. 1-7)

The bottom of the camera has tripod sockets for both 3/8"-16 and 1/4"-20 screws (conforming to ASA standard PH3.7-1952). It also contains an electrical connector for use with any handgrip. Handgrips attach to the camera through a mounting plate and are adjustable to provide a wide range of holding angles to suit individual preferences. They incorporate a push on/push off switch to control camera operation. Refer to Camera Options and Accessories section for a description of available handgrip controls.

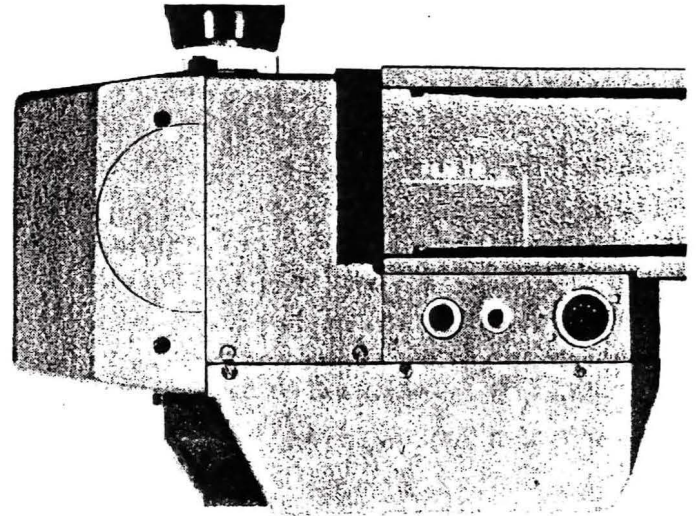

Figure 1-7. Bottom of Camera

SIDE COVER (Fig. 1-8)

The side cover permits access to the inside of the camera and includes a channel for insertion of the NC-4 battery pack. A release latch (1) at the right end of the channel must be depressed to insert or remove the battery pack. Upon insertion, the battery automatically makes electrical connection to the camera.

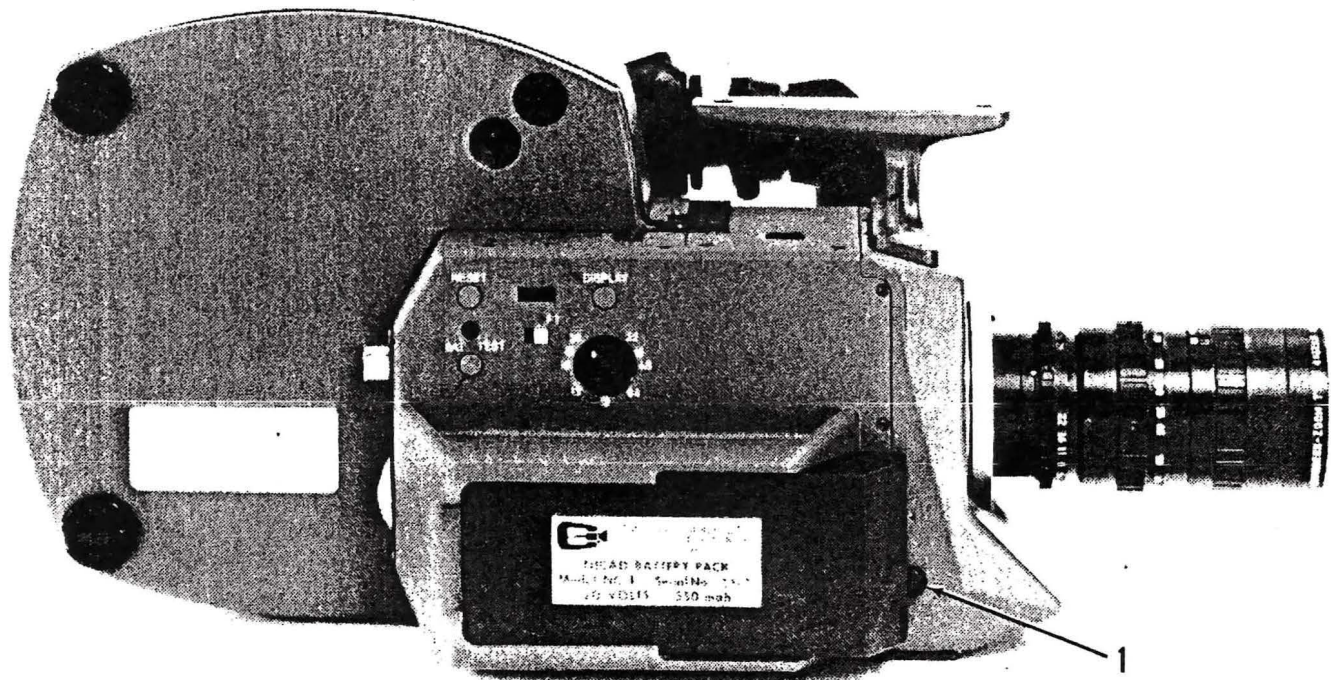
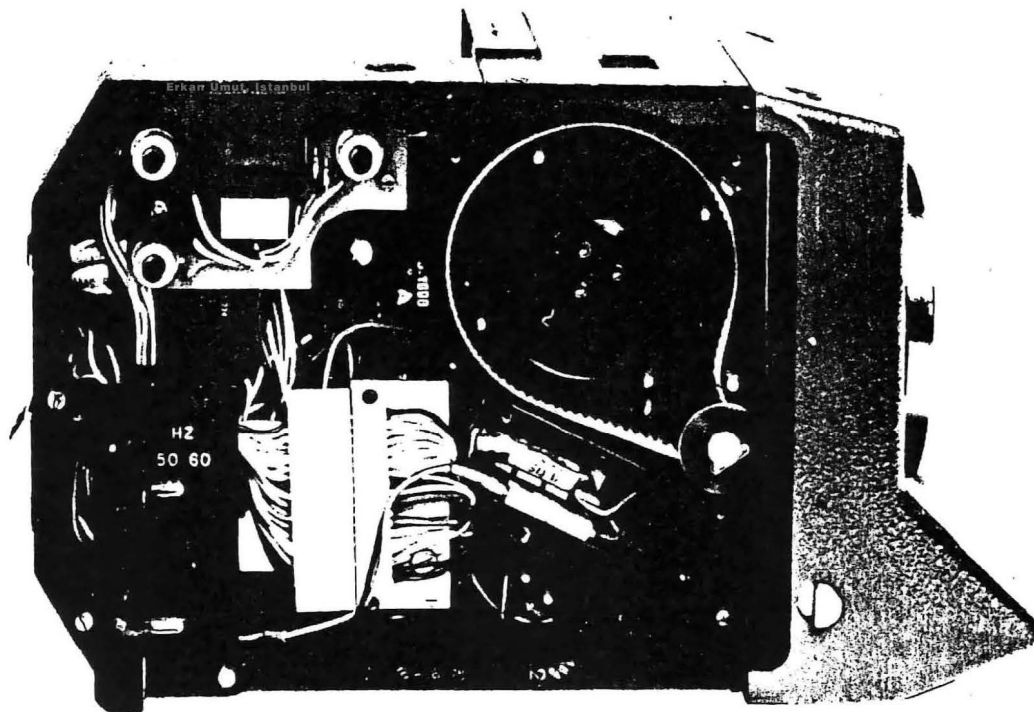

Figure 1-8. Side Cover

CAMERA DRIVE (Fig. 1-9)

The camera is driven by a crystal-controlled motor and geartrain. The motor is embedded in the solid aluminum camera frame for maximum noise attenuation. Drive system electronics are packaged on an extremely compact circuit board using CMOS logic and hybrid electronic circuits. In addition to crystal-controlled step-variable speeds of 12 to 64 fps, the circuit board also provides autoslating and pilotone outputs to an external sound recorder. The circuit board also contains the digital footage counter.



Note: 50/60-Hz selector switch which is normally concealed when battery is in place is visible from outside cover. Use 1/8-inch-blade screwdriver to adjust.

Figure 1-9. Camera Drive

APERTURE PLATE AND FILM TRANSPORT (Fig. 1-10)

The film transport movement consists of a high-precision, single-claw sinusoidal registration movement, with a curved film gate for minimum pull-down time. The interchangeable film gate assembly with its floating pressure plate and hard-chrome-edge film guides is located in the film magazine.

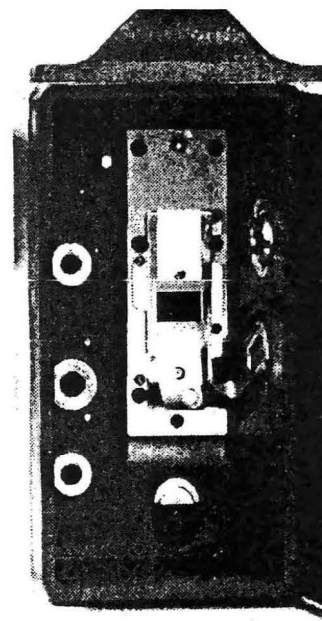

Figure 1-10. Film Transport

LENS MOUNT (Fig. 1-11)

The positive-locking CP lens mount assures perfect alignment with the film transport. The locking provides positive locking against the lens flange so that there is no possibility of lens movement and eliminates lens flange wear, since there is no twisting or torquing motion required. To prevent accidental rotation of the lens, there is a special locating pin (1) installed on the top of the lens mount. Many lenses may be either converted or adapted to fit the CP lens mount.

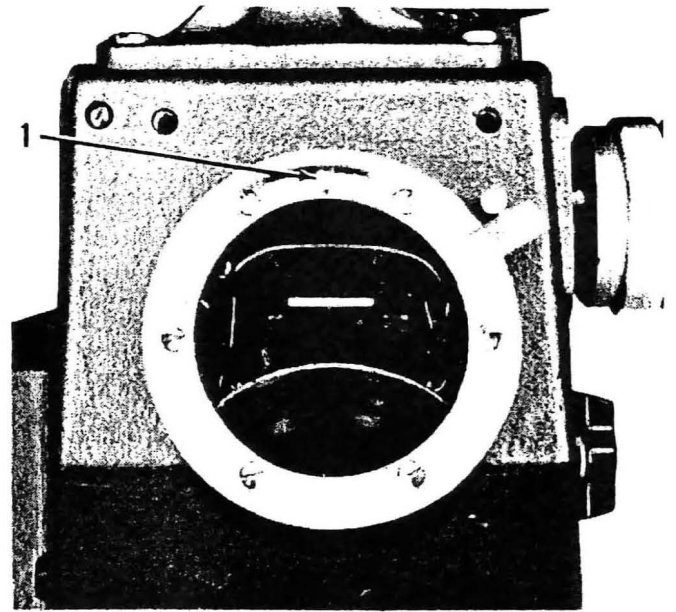

Figure 1-11. Lens Mount

MAGAZINES

Two sizes of magazines are available from Cinema Products for GSMO cameras: the 400 ft (120m) (figure 1-12) and 100 ft (30m). These quick-change, cassette-type coaxial magazines, intended for rugged use, incorporate loop-forming devices for quick and easy loading. Preloaded magazines can be changed instantly. The interchangeable film gate assembly, installed in the magazine, has a removable pressure plate for easy cleaning. The 120m (400 ft) magazine also features a film-remaining manual indicator which reads: "E- $\frac{1}{4}$ - $\frac{1}{2}$ - $\frac{3}{4}$ -F." Magazine door locks (1) are used when loading or unloading magazine.

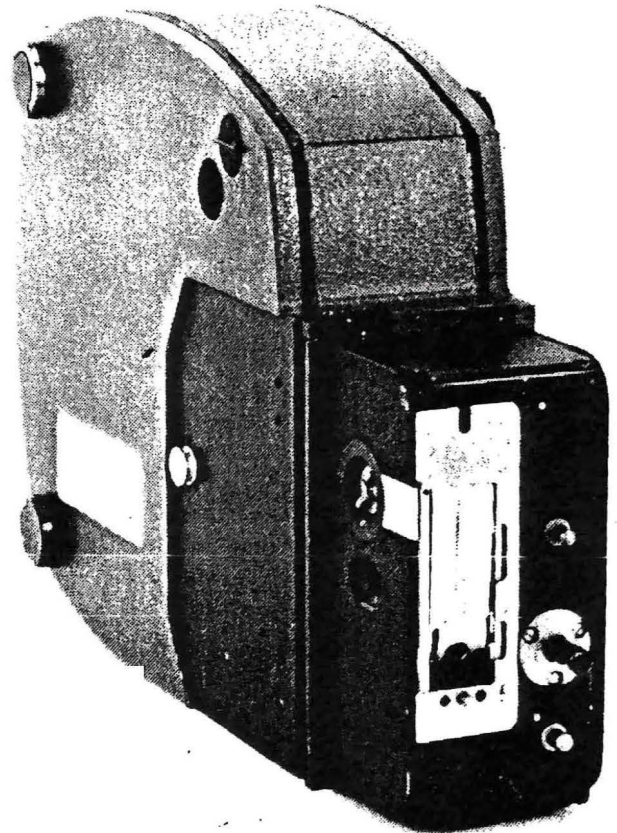

Figure 1-12. 400-Foot Magazine

POWER SUPPLIES

NC-4 BATTERY PACK (Fig. 1-13)

The ultracompact and lightweight NC-4 nicad battery weighs only 16 oz. (454 gr.) and measures 5" long x 1-1/4" high x 2-1/8" wide (12.7 cm x 3.2 cm x 5.5 cm). A fully charged spare NC-4 will easily fit into a shirt pocket. A single NC-4 battery pack supplies all the required power for camera operation.

The NC-4 battery pack automatically makes electrical connection to the camera upon insertion in the battery channel, located on the side of the camera. It is easily and almost instantly clicked into or out of its position in the camera battery channel. The NC-4 casing is made from rugged, high-impact glass-filled Lexan. The NC-4 battery contains a 30-amp fuse to prevent damage or injury in case of a short circuit.



Figure 1-13. Battery Pack

Battery rating: 20 volt, 550 mah.

Battery capacity: drives approximately 1600 ft. (500m approx.) 16mm film on a single full charge.

Note

Battery capacities vary depending on temperature extremes. Amount of film driven on a single full charge will also vary, depending on the number of different accessories being powered by the same battery.

Note

To prevent accidental battery power drain when not filming, battery may be inserted into battery channel in reverse position—with identification plate facing inward and contact points facing front of the camera. The battery will click into position as usual.

NCC-6 BATTERY CHARGER (Fig. 1-14)

The NCC-6 battery charger charges individual NC-4 battery packs. The NCC-6 features a charging status indicator light and current regulation. Input voltage switchable to 95-130 or 190-260 vac range (60 or 50 Hz, single-phase supply). The NCC-6 fully charges an NC-4 battery in approximately 14 hours.

Note

The NCC-6 charging status indicator light signals that the charger is connected to the battery and is operating correctly. It does not indicate the charge status in the NC-4 battery pack. A warm battery generally indicates a fully charged battery.

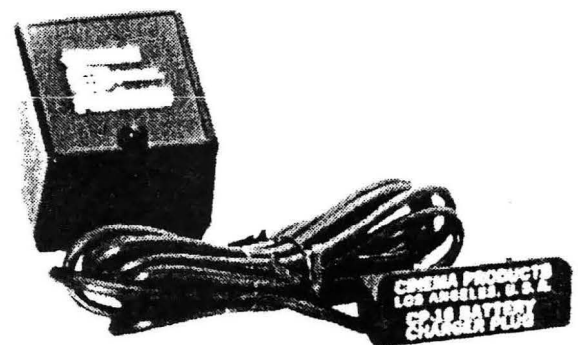

Figure 1-14. Battery Charger

MBC-6 MULTIPLE BATTERY CHARGER

Charges up to six NC-4 nicad battery packs simultaneously. The MBC-6 multiple battery charger operates, with switch selection, to 115 or 230 VAC, 60 or 50 Hz, single-phase supply.

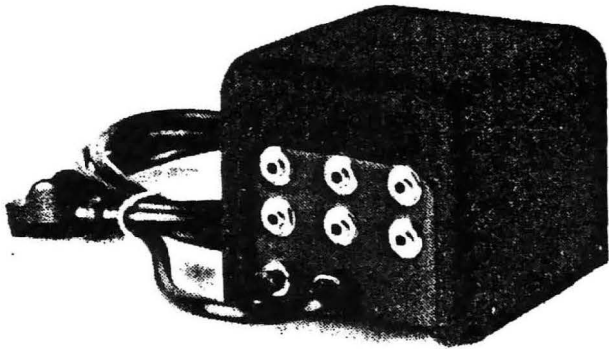

Figure 1-15. Multiple Battery Charger

BATTERY CHARGER CABLE

For use with multiple battery charger (Model MBC-6) when charging NC-4 nicad batteries.

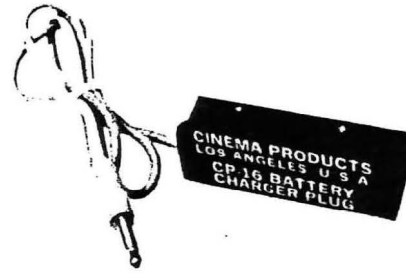

Figure 1-16. Battery Charger Cable

REMOTE-OPERATION BATTERY CABLE (Fig. 1-17)

Permits removal of the NC-4 nicad battery pack from cameras for placement in the cameraman's pocket (or some other protected area) when filming in extreme cold. A power adapter (dummy battery) is placed in the battery compartment of the camera; the cable connector is attached to the dummy battery.

Note

When filming in extreme cold while in an airplane, it is possible to connect the remote-operation battery cable (by changing the battery plug) to operate from the typical 24-VDC power sources available on aircraft (up to a maximum of 28 VDC) and to drive the camera from this auxiliary power source. (Other 24-VDC power sources such as dry cells, lantern batteries, etc., may also be used in a similar manner.)

Caution: When operating in this mode, it is extremely important to observe correct polarity.

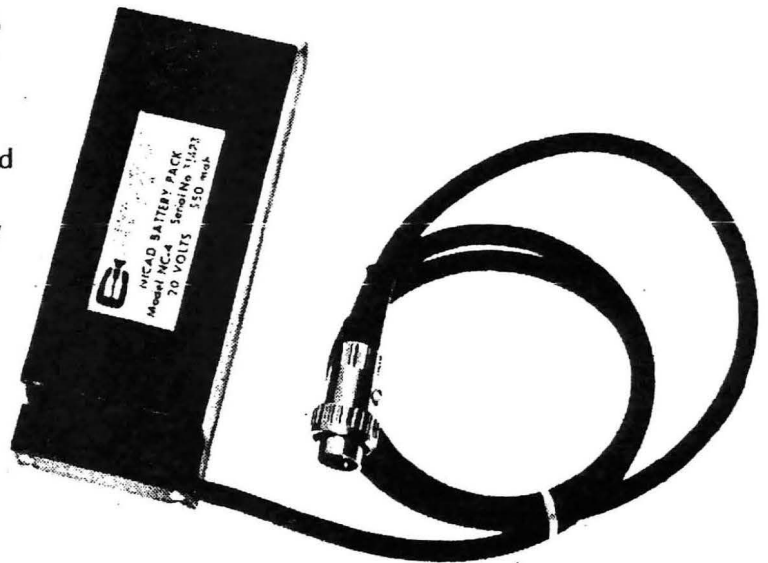

Figure 1-17. Remote-Operation Battery Cable

USE OF ACCESSORY CONNECTOR

The accessory connector (ACCY) is located at the back of the camera above the RUN/STOP switch (figure 1-4). The mating connector is a T.M.W. R05PB8M(CP stock No. CON-033265). Pin functions and limits are:

Pin	Function	Limit
A B C	+10 volts Switched B+ GROUND RETURN	50 ma maximum draw (limited). 300 ma maximum draw (fused). 500 ma maximum return (unprotected).
D	PILOTONE 50-60 Hz	The tape recorder's pilotone input must have a DC resistance between 1,000 and 27,000 ohms. (See figure 1-9 for location of switch.)
E F G H	External speed SLATE SPARE B+ (20 volts)	Refer to factory for information. Provides a 10V, 10-ma output simultaneously with film mark. 300 ma maximum draw (fused)

REMOTE RUN/STOP CONTROL

For remote control of camera RUN/STOP function, connect an external switch as shown in figure 1-18. The DC resistance of this circuit must be less than 2.0 ohms. A 5-foot cable is available from the factory.

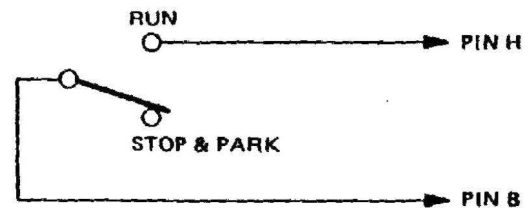

Figure 1-18. Remote RUN/STOP Switch

CONNECTING PILOTONE/AUTOSLATE TO RECORDER

To use the pilotone generated by the camera for control of an associated tape recorder, connect the pilotone signal to the recorder pilotone circuit as shown in figure 1-19. If the pilot input on the tape recorder shows an open with an ohmmeter, install a 10K resistor (R_L) in the connector as shown. Use shielded wire for long runs. Be sure to select 50 or 60 Hz (figure 1-9).

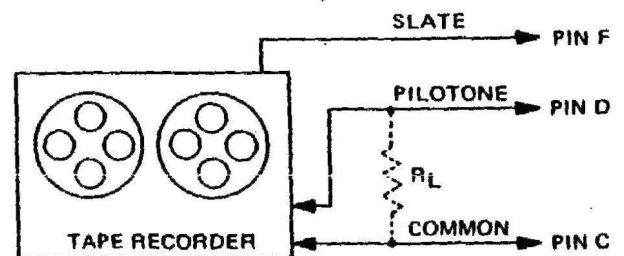

Figure 1-19. Control of Tape Recorder

PILOTONE/AUTOSLATE SEQUENCE (Fig. 1-20)

When the camera is turned on, a lamp inside the camera is lighted for 0.33 second to fog the film and produce a film start mark. Automatically, a "slate" pulse is generated on pin F of the accessory connector to synchronize a recorder so equipped. The pilotone signal appears on pin D (figure 1-20).

NOTE: GSMO will fog film and/or slate recorder only when a recorder or other load is connected to pilotone connection (pin D).

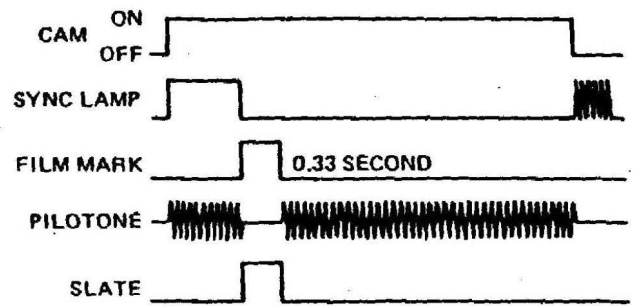

Figure 1-20. Pilotone/Autoslate Sequence

FUSES

A 5-amp fuse is located on the battery connector assembly, covered by the battery. To replace, remove battery and pull out fuse (Littlefuse P/N 276.005, CP stock No. FSE-125045).

A one-inch length of 30 AWG wire is mounted on the rear of the battery connector assembly. It will melt at about 20 amps. If this safety wire melts, look for major short in the motor drive circuit.

SECTION 2 – OPERATION

INTRODUCTION

This section is directed to the camera operator of GSMO cameras. If this section does not answer all questions regarding operation of the camera, please contact the dealer or factory for further information.

RECEIVING THE CAMERA

The factory has shipped the camera after thorough inspection and testing. A test film demonstrating camera movement steadiness and a full checkout report are provided with each camera. Packing is done with care and shipping effected according to customer's instructions. The camera should be carefully unpacked and thoroughly inspected as soon as it is received. (Be sure to remove any loose bits of packing materials that may cling to various parts of the camera.) If any damage is found, file a claim directly with the transportation company and notify your dealer or the factory.

CAMERA CHECKOUT

After inspection, insert a fully charged NC-4 battery pack into the battery channel, push the battery test button on the control panel, and check the battery test light and footage display. Rotate the magazine lock knob to the lock position, then operate the RUN/OFF switch on the switch panel or the trigger button switch on the handgrip. With camera running, inspect mechanism for claw action, mirror shutter and magazine drive for rotation. Note that the red out-of-sync warning "S" lights up briefly in the viewfinder each time the camera starts up from rest, and stops.

ON-OFF SWITCHES: The handgrip trigger on-off button and rear panel RUN/OFF switch are connected in parallel. Both switches must be in the off position in order to stop the camera. Also note that the switch in the on position will override the other switch in the off position. (Note: Camera will not run unless magazine lock knob is in the lock position.)

If any problems are experienced, reference should be made to your dealer or the factory.

LOADING MAGAZINES

Magazine supply side may be loaded in a dark room or in a changing bag.

1. **Center Button:** Daylight spools and core adapters lock into place by depressing the center button. Also use center button to release core adapter or daylight spool.
2. Remove door on supply side of magazine (in 400-ft magazines, door with film-remaining counter) by loosening two magazine door locks.
3. Place end of film in film cutter (on inside of door, figure 2-1) and clip.

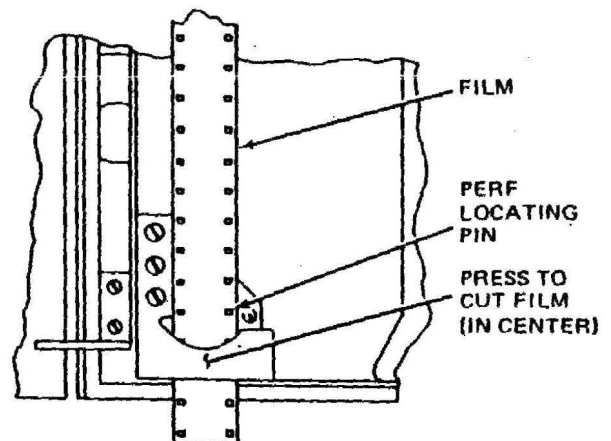

Figure 2-1. Film Cutter

LOADING MAGAZINES (contd.)

4. Insert film into slot above roller with emulsion up (figure 2-2).
 5. Push film through slot until you feel the perforations engaging the teeth on the feed sprocket (figure 2-2).
 6. Rotate feed sprocket counterclockwise and feed film into front compartment of magazine (figure 2-2).
 7. Place remaining roll of film onto magazine core adapter. Recheck center button for correct seating of core adapter or spool. Replace door and lock.
- Note: The remaining steps may be done in subdued light.
8. Remove door from takeup side of camera by loosening two door locks.

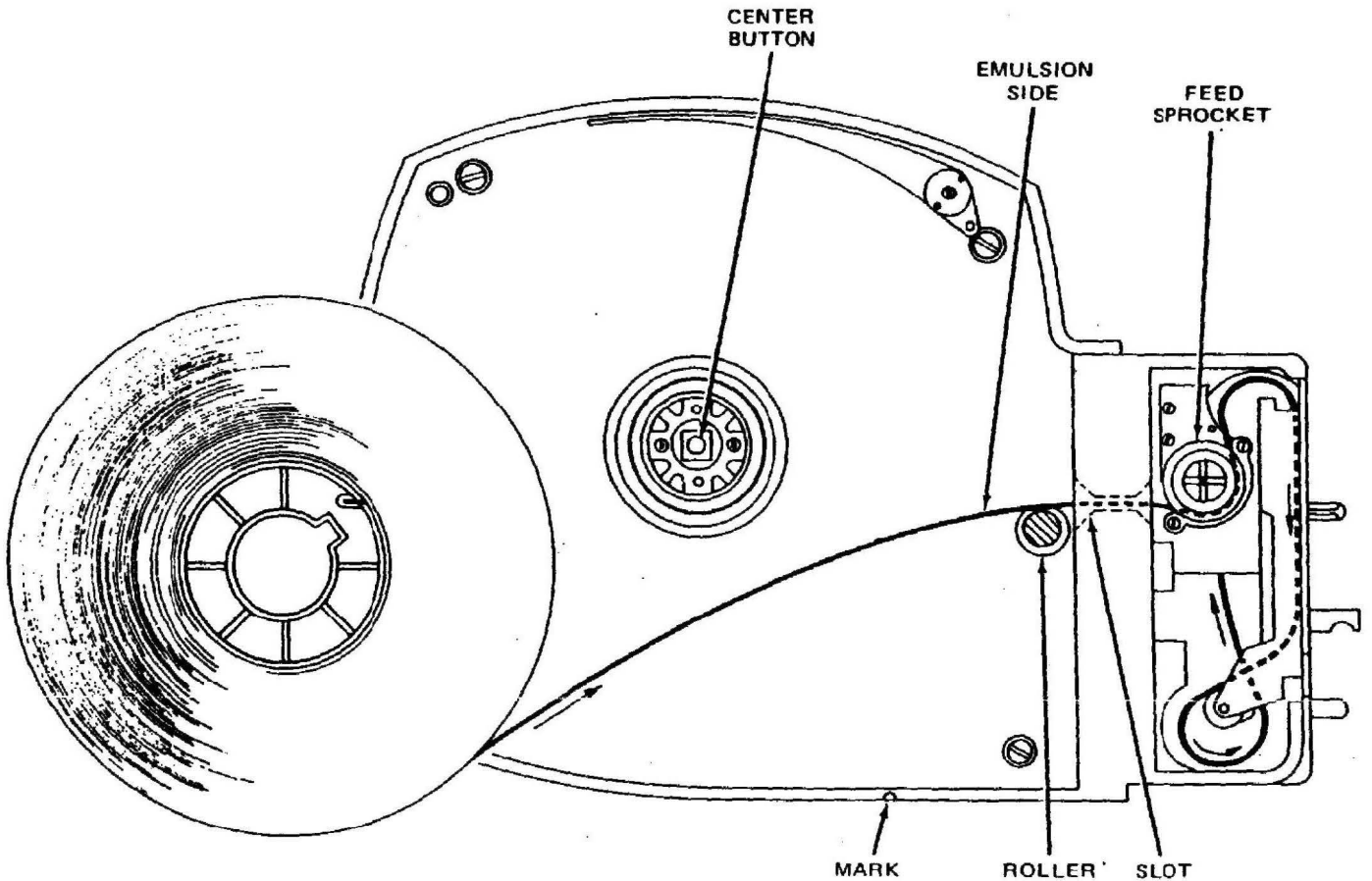

Figure 2-2. Threading Film on Supply Side of Magazine

LOADING MAGAZINES (contd.)

9. Turn takeup sprocket (figure 2-3) clockwise until film appears in gate (figure 2-4).
10. Continue to turn takeup sprocket clockwise to advance film through gate until the cut end reaches the mark on the bottom of the magazine (figure 2-2).
- Caution:** Do not pull the film.
11. Place supply side of magazine down and insert film into lower gate opening. Film will form a spiral loop as shown in figure 2-3.
12. Insert end of film into takeup sprocket (figure 2-3) and turn sprocket clockwise. Push film loop down over film end roller and under guide roller (figure 2-3).
13. Continue to turn takeup sprocket clockwise to advance end of film through light trap and under takeup roller (figure 2-3).
14. Wrap end of film around takeup core (figure 2-3). Check seating of core.
15. Replace door on takeup side of magazine and lock.

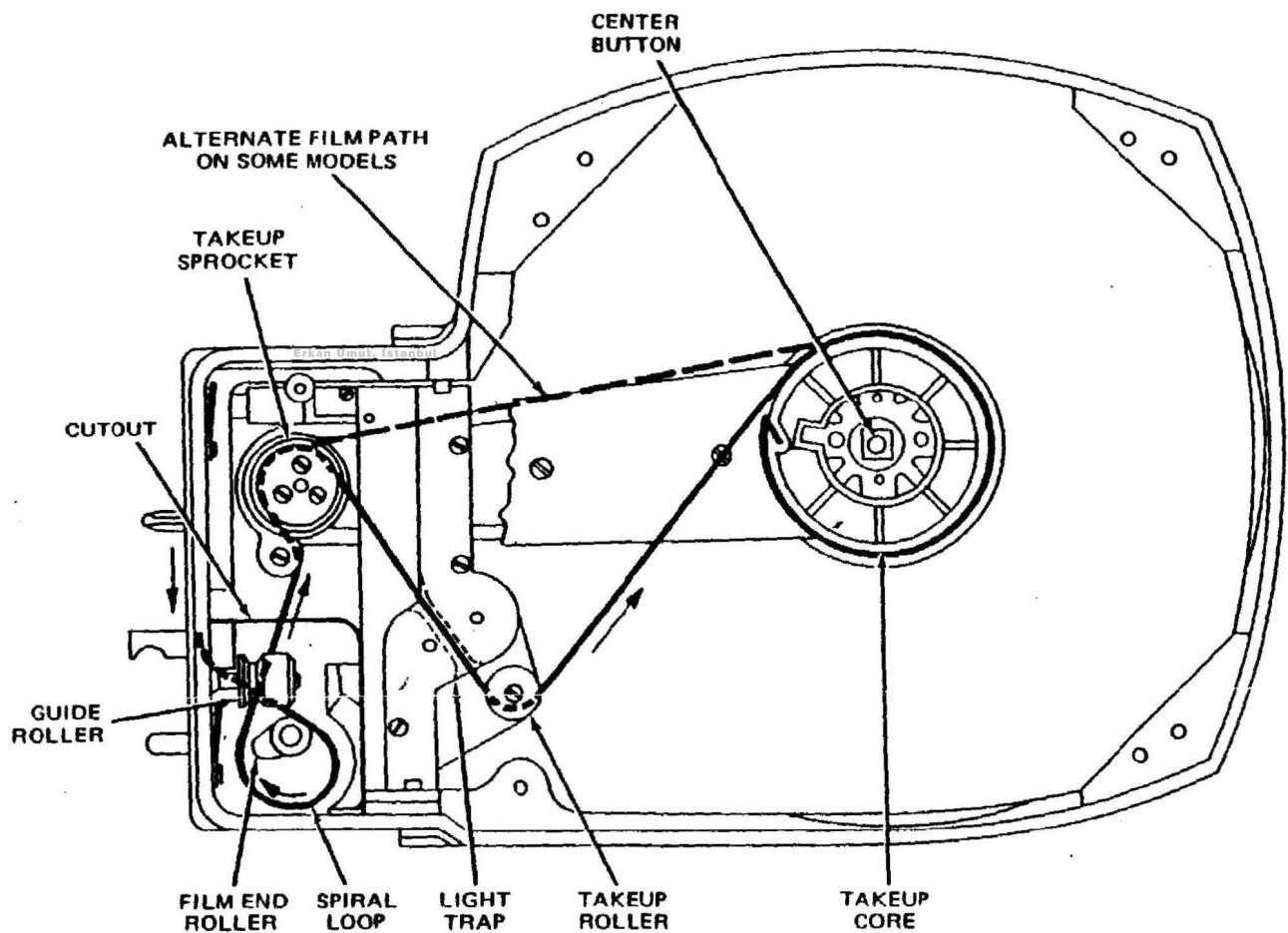

Figure 2-3. Threading Film on Takeup Side of Magazine

LOADING MAGAZINES (contd.)

16. Push the film all the way up in the gate (figure 2-5).
17. Insert magazine into camera and rotate magazine lock (12, figure 1-2) to LOCK position.

Note: When removing magazine from camera, rotate lock (12, figure 1-2) to OPEN and release latch (13, figure 1-2), if necessary.

18. Run one to two feet of film through camera, remove magazine and check exposed film for scratches. If scratches are found, check film gate for cleanliness or burrs.

Note: While filming, check cleanliness of film gate from time to time by:

- a. Removing lens.
 - b. Moving shutter aside by carefully rotating in counterclockwise direction with finger touching black portion only.
 - c. Checking gate through shutter aperture for lint, hair, film pieces, or any other contamination and cleaning as necessary.
19. Verify film is pushed up in gate (figure 2-5) each time magazine is inserted.

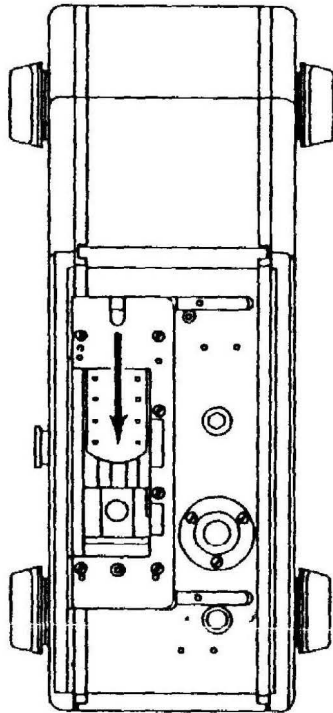

Figure 2-4. Film Projects Through Gate

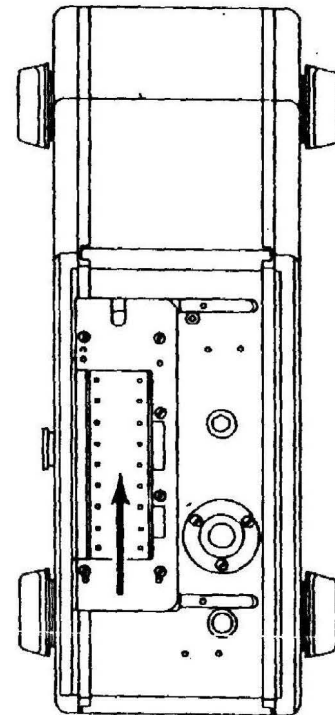

Figure 2-5. Film Pushed Up Properly in Gate

REMOVAL OF MAGAZINE

To remove magazine, rotate lock (12, figure 1-2) fully clockwise to OPEN and slide release latch toward battery (13, figure 1-2). Pull magazine away from camera body.

INSTALLATION OF LENSES

The GSMO has a positive-locking CP lens mount which can accept a wide range of CP-mounted lenses.

To prevent accidental rotation of the lens, there is a special locating pin (1, figure 1-11) installed on the top of the lens mount. Position the lens in the mount, locating the pin key to the top, and tighten the lens lock ring in a clockwise direction until firmly engaged. DO NOT OVERTIGHTEN.

Note: The lens cavity cap should always be in position in the CP lens mount (when not using a lens) to protect camera from dust, etc.

IMPORTANT FEATURES TO CHECK BEFORE FILMING

1. Check battery pack by pressing BAT TEST switch and observe that battery indicator comes on. A fully charged NC-4 battery pack can drive approximately 1,600 feet of film. Accessories and/or extreme cold will reduce this footage. (Note: It is a good practice to put the used battery pack on charge as soon as possible after filming.)
2. Check switches. Operate the camera using both the rear RUN/STOP switch and the switch on any handgrip or remote control device in use.
3. Check magazine seating. Magazine lock must be fully counterclockwise to close camera run interlock switch.
4. Check lens installation. Lens must be seated snugly.
5. On cameras with semiautomatic or fully automatic exposure control, set FILM SPEED control to ASA/DIN rating of film.
6. Set frame rate selector to desired frame rate.
7. Set M/FT to M (meters) or F (feet) as desired. Reset counter if desired (page 1-4).
8. Check auxiliary systems carefully.
9. Check film flow with a short burst of a few feet of film.
10. Check exposure indicators in viewfinder. To correct over- or underexposure, rotate lens iris control ring until exposure control information display indicates "0."

SECTION 3 – CAMERA ACCESSORIES AND OPTIONS

ORIENTABLE VIEWFINDER

The Cinema Products orientable viewfinder (figure 3-1) was designed with a unique optical path in which the optics fold forward so that the eyepiece is approximately 1 inch (25mm) behind the film plane as it is in the standard viewfinder. The CP erect image orientable viewfinder permits left-eye viewing without requiring any additional accessory.

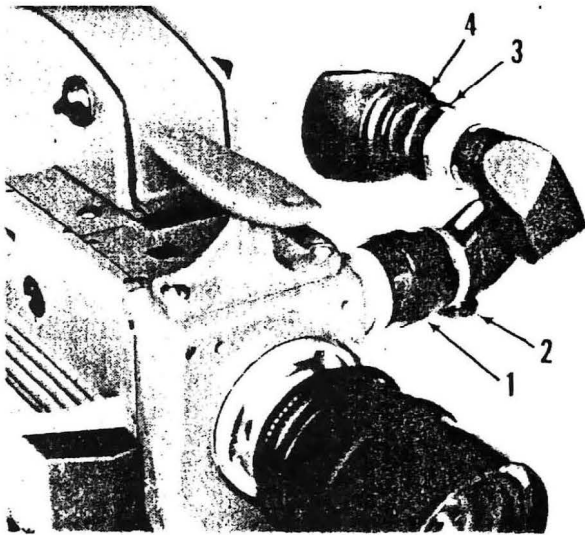

VIEWFINDER IN NORMAL POSITION

- (A) NORMAL POSITION
- (B) EXTENDED POSITION
- (C) TOP VIEWING POSITION

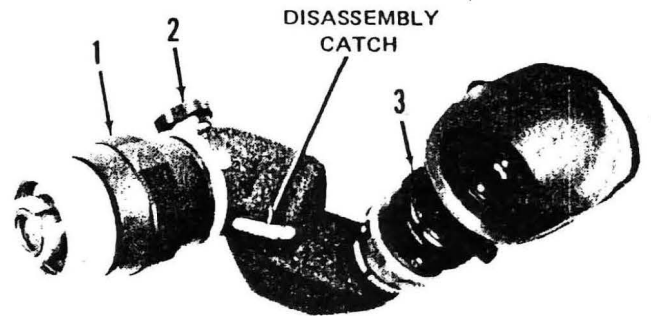

ORIENTABLE VIEWFINDER

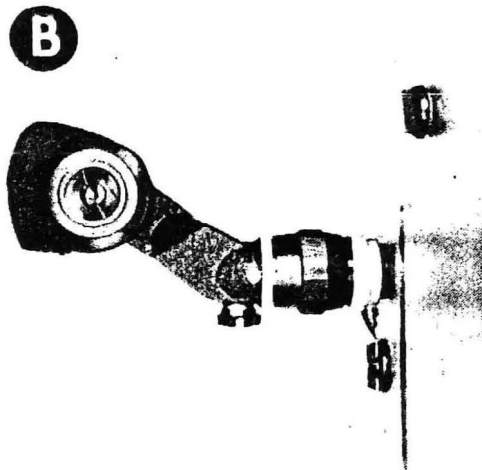
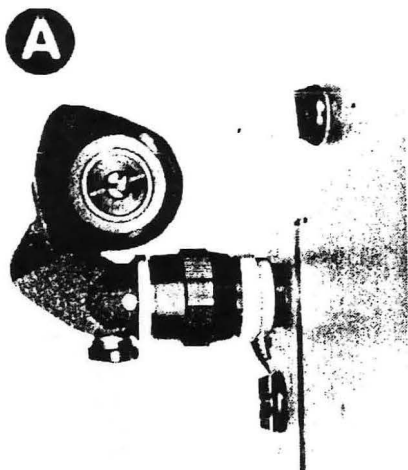

Figure 3-1. Orientable Viewfinder

There are four controls on the orientable viewfinder: the viewing position lock (1, figure 3-1) and the image orientation lock (2), in addition to the eyepiece diopter adjustment ring (3) and eyepiece "dowser" open/close control ring (4). The eyepiece diopter adjustment ring provides ± 5 diopters of adjustment.

Releasing the viewing position lock allows rotation of the viewfinder through a full 360 degrees while the orientation of the image in the eyepiece remains constant. Turn cw to lock, ccw to release.

Releasing the image orientation lock allows the image to tumble as the viewfinder is rotated. This permits the image to be oriented to the operator's viewing position. (The operator may view from any position and still see the image in the correct viewing orientation.)

EXTENSION TUBE ASSEMBLY

The eyepiece of the orientable viewfinder may be removed and an extension tube assembly (figure 3-2) inserted between the viewfinder body and eyepiece.* The extension tube assembly moves the eyepiece approximately 7" (178mm) behind the film plane for more convenient viewing when the camera is mounted on a tripod or dolly.



EXTENSION TUBE ASSEMBLY



*Note: The eyepiece simply unscrews from the body of the orientable viewfinder and screws onto the extension tube assembly. When the extension tube assembly is placed on the orientable viewfinder, the image is automatically rotated 180 degrees. To reverse this image orientation, loosen the image orientation lock and rotate the finder 180 degrees. Tighten the lock and rotate to viewing position.

Figure 3-2. Extension Tube in Use on Tripod-Mounted Camera

SEMI-AUTOMATIC EXPOSURE CONTROL

DESCRIPTION. The semiautomatic exposure control is a through-the-lens (TTL) system utilizing a silicon light sensor for fast response at low light levels. The sensor is less responsive to sun, bright skies, and overhead lighting across the upper portion of the film frame, thus emphasizing correct exposure of the subject. Figure 3-3 shows the weighting diagram and explanation. Light is measured in the viewing system, so no light is ever diverted from the film.

OPERATION. Power for both semiautomatic and fully automatic exposure control systems is controlled by the RUN switch on the switch panel at the rear of the camera as described in figure 1-4.

ASA or DIN film speed is set using the film speed knob on the switch panel at the rear of the camera. Since the sensor measures light through the lens, filter factor exposure compensation is automatic. *Do not* compensate the ASA or DIN setting for the filter being used.

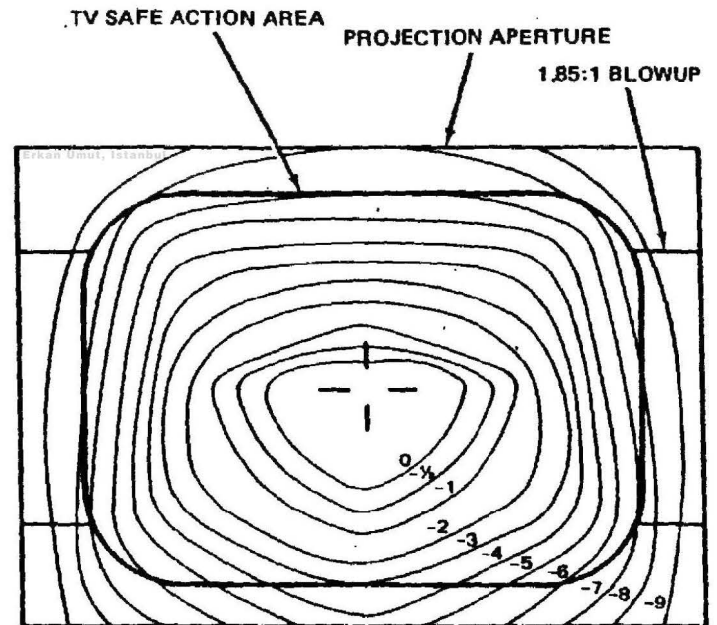

Note: Figures represent stops relative to central area sensitivity.

Figure 3-3. Exposure System Weighting Diagram

Exposure compensation for camera frame rate is internal and completely automatic for any frame rate even when remote speed control option is used.

Figure 3-3 represents the weighted response of the GSMO exposure control system to images in the camera's picture area as seen on the fiber optic viewing screen. The areas bounded by continuous lines represent values of uniform exposure control system weighting relative to the most sensitive region located at the center of the picture area. The numbers identifying these areas indicate the number of stops (t/ or f/) that a particular area is dewighted.

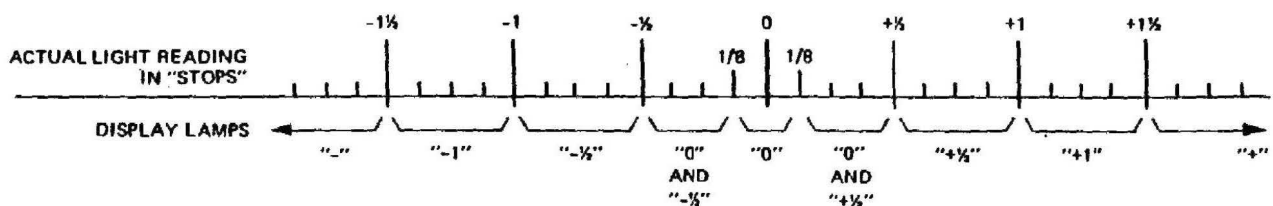

Interpretation of Lights

FULLY AUTOMATIC EXPOSURE CONTROL

DESCRIPTION. The fully automatic exposure control is an option for the semiautomatic exposure control system previously described. A lens-mounted servomotor is connected to the camera via short cable. The motor operates the iris control ring (using gears) until proper exposure is obtained. The viewfinder will display exposure information.

OPERATION. The fully automatic exposure control system is activated when the power switch on the end of the servomotor is switched on. The servomotor will then position the iris control of the lens to the correct setting. The servomotor will "slip clutch" at the extremes of iris control rotation if the light is too much or too little for proper exposure. When this happens, switch off the servomotor to conserve battery power.

The lens may be operated manually by switching off the servomotor. The viewfinder display will continue to show exposure information.

J-5 ZOOM CONTROL SYSTEM

GENERAL. The J-5 zoom control system (figure 3-4) is designed for use with all GSMO camera models. The J-5 zoom control system consists of a silent servo zoom motor and a specially designed J-5 camera handgrip control*, plus appropriate zoom lens gear and motor support bracketry. Special gear and bracketry sets are required when using the J-5 zoom control in conjunction with a camera equipped with fully automatic exposure control.

The J-5 servo feedback system circuitry and thumb-activated direction/proportional speed control are all compactly packaged inside the J-5 camera handgrip. The J-5 handgrip also contains the camera on/off switch.

The silent servo zoom motor delivers full maximum torque at all speeds. The J-5 zoom motor permits a full zoom at maximum speed in 2½ seconds—while providing continuously variable speeds up to maximum speed rating.

OPERATION. Plug one end of the J-5 motor cable into the J-5 zoom motor and plug the other end into the J-5 handgrip control. The coil cable from the camera baseplate plugs into the J-5 handgrip control. The zoom motor attaches to the motor support bracket through an eccentric which allows for adjusting the lens gear mesh for optimum operation.

J-5 lens gear and zoom motor support bracketry sets are available (as specified) for the wide range of zoom lenses which can be used with the GSMO camera system. (Detailed mounting instructions are supplied with each J-5 gear and bracketry set.)

*Note: The J-5 zoom control system utilizes the universal mounting plate. Refer to the shoulder pod/handgrip section on page 3-7 for installation instructions.

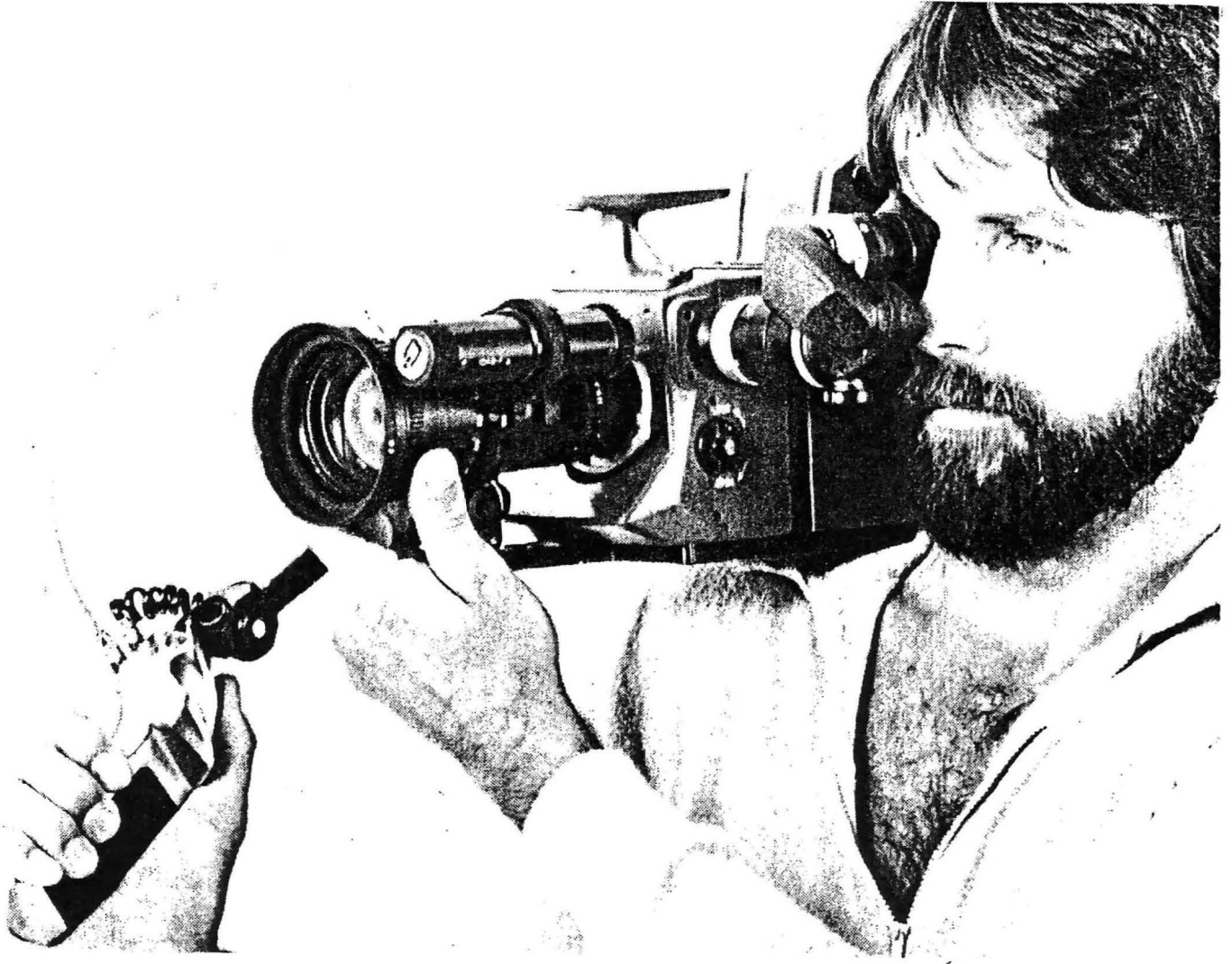

Figure 3-4. J-5 Zoom Control

HANDGRIPS AND SHOULDER POD/HANDGRIP

GENERAL. Three handgrips and one shoulder pod/handgrip are available for the GSMO. The three handgrips all use the same universal mounting plate and are attached to the camera similarly. The shoulder pod is part of a quick-release system.

DESCRIPTION. The standard handgrip is compact and lightweight and contains a thumb-operated RUN/STOP switch (figure 3-7).

The extension handgrip is similar to the standard handgrip except that it has an adjustable extension for versatility (figure 3-8). A RUN/STOP switch is also provided.

The J-5 power zoom handgrip also has an adjustable extension (figure 3-4). In addition, it has an electronic power zoom control built into the handgrip for operating a lens-mounted servomotor. A RUN/STOP switch is provided. Specific instructions regarding the J-5 are on page 3-4.

The shoulder pod/handgrip (figure 3-6) uses a quick-release plate attached to the bottom of the camera to allow quick interchanging of the camera between shoulder pod and tripod. A curved, padded support and RUN/STOP switch are provided.

INSTALLATION. To attach the universal mounting plate used with the standard, extension, and J-5 handgrips:

1. Remove and save three large screws from black camera baseplate. Set baseplate aside; it will not be used.
2. Align electrical contacts and attach universal mounting plate to bottom of camera using screws removed in step 1.
3. Attach specific handle support knuckle to universal mounting plate with four captive screws in knuckle.
4. Install camera battery, rotate magazine lock to LOCK, and verify proper RUN/STOP switch action.

To attach the shoulder pod/handgrips:

1. Attach quick-release plate to bottom of camera using screw provided. Do not remove camera baseplate.
2. Rotate lock knob on shoulder pod to open position. It will click into position.
3. Position camera so electrical contacts align and lower camera into shoulder pod until lock knob rotates automatically.
4. Snug lock knob and check for a secure fit.
5. Verify RUN/STOP switch as in step 4 above.
6. To remove, rotate lock knob until it clicks into open position. Lift camera from shoulder pod.

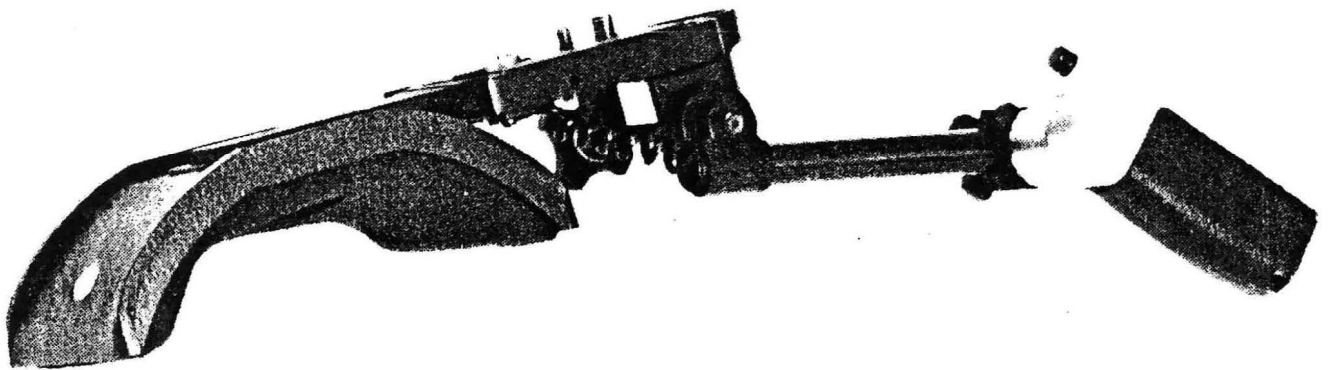

Figure 3-6. Shoulder Pod Handgrip

The snap-latch mounting system may also be used in conjunction with either the compact handgrip (figure 3-8) or the extension handgrip (figure 3-9).

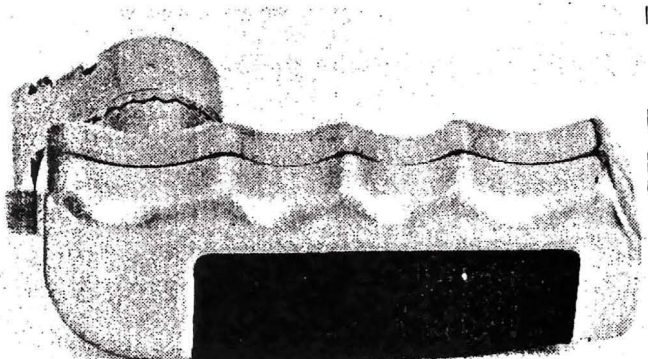

Figure 3-7. Compact Handgrip



Figure 3-8. Extension Handgrip

CARRYING CASE

A specially designed and fitted carrying case to accommodate cameras, magazines, and camera accessories is available from Cinema Products (figure 3-9).

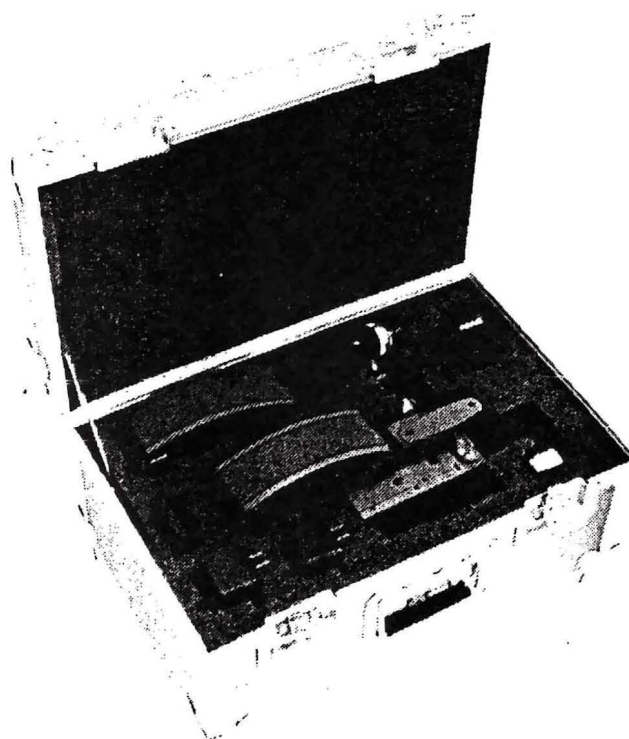

Figure 3-9. Fitted Carrying Case

STEADICAM

The GSMO camera can be used with Cinema Products' Steadicam[®] system (figures 3-10 and 3-11) to permit a broader range of handheld shots than otherwise possible. Steadicam is a camera stabilizing system which permits handheld shots of the steadiness usually found only on dollies or booms, yet it has the flexibility limited only by the cameraman's imagination.

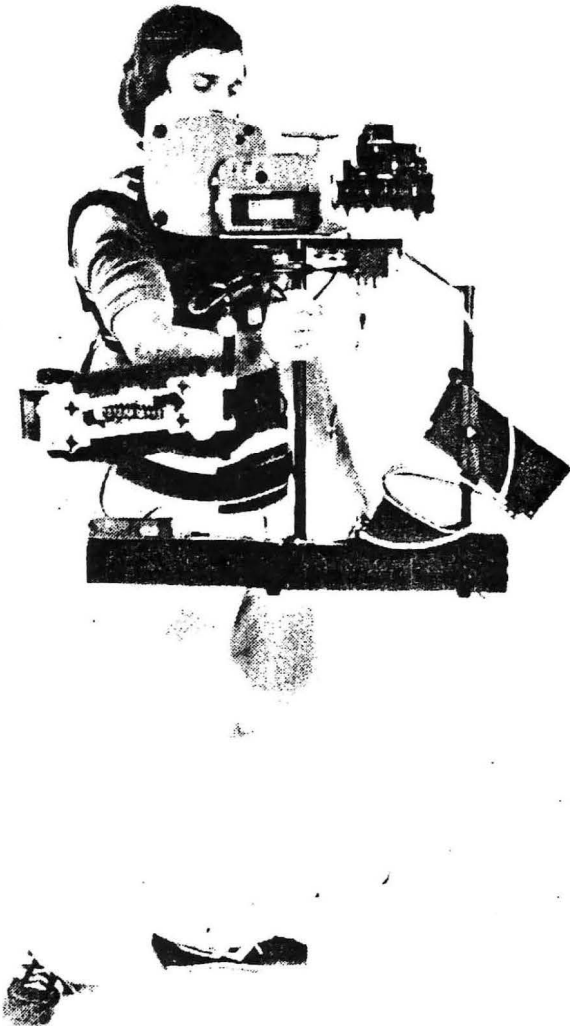

Figure 3-10



Figure 3-11

SECTION 4 – FUNCTIONAL DESCRIPTION

MOTOR DRIVE SYSTEM

The electronic circuit elements of the GSMO camera are shown in the system block diagram, figure 4-1. Each element is described in the following paragraphs. The electrical schematic diagram for the camera is shown in figure 4-10.

REFERENCE OSCILLATOR. The reference oscillator produces a stable 30-kHz signal which is the control signal for all camera functions. The 30-kHz output provides the drive motor signal, sawtooth signal for the pulsewidth modulator, and the pilotone signal available at the accessory connector.

Integrated circuit U1 is a crystal-controlled oscillator hybrid circuit. It contains the circuitry necessary to produce a 30-kHz output from the 3.84-MHz crystal input. An oscilloscope can be connected to the 30 kHz to check the oscillator.

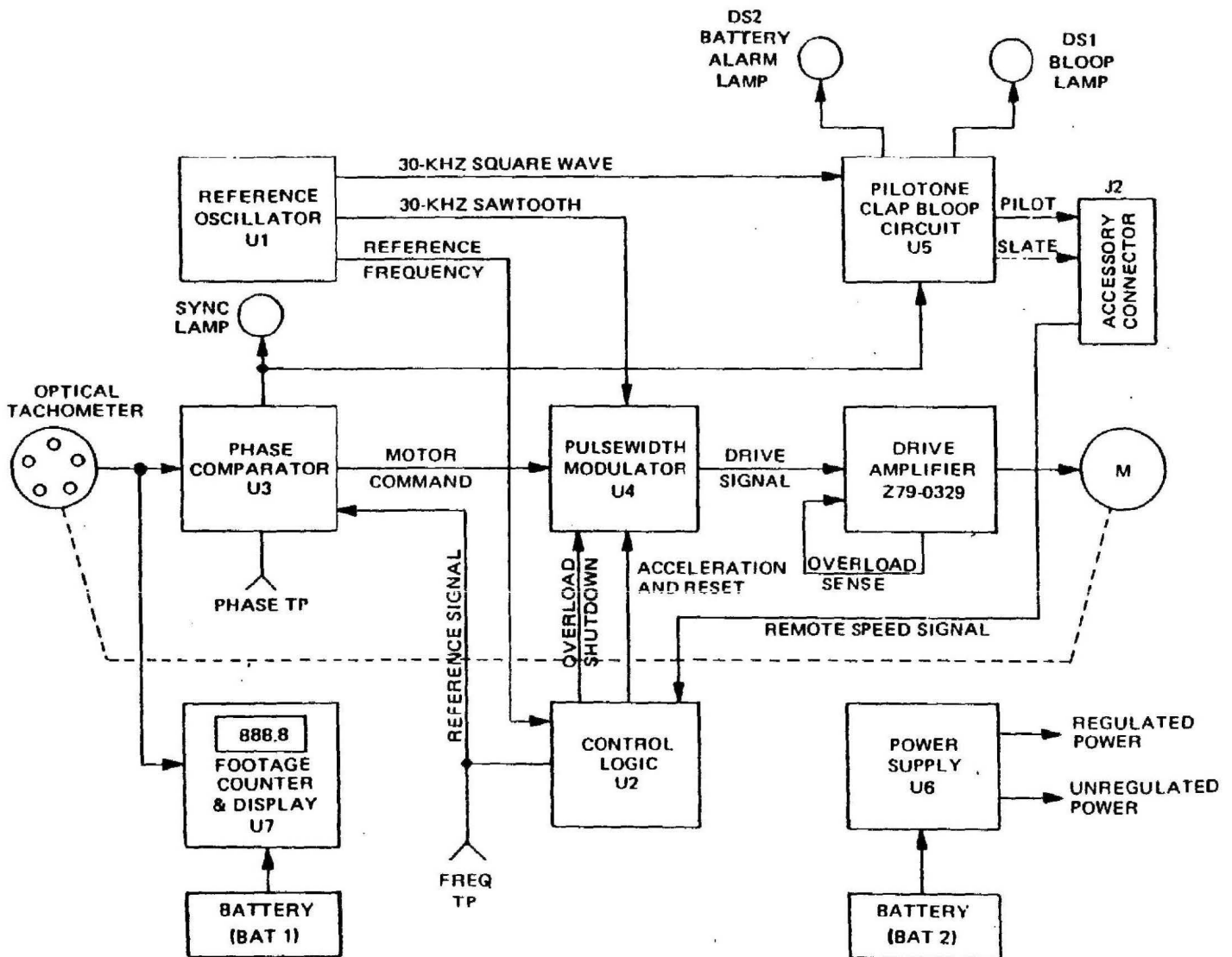

Figure 4-1. GSMO Camera Electronic Block Diagram

The 3.84-MHz input is divided down to the phase comparator's reference frequency by a series of binary dividers and a diode matrix. Pins 1-6 and 9 make up the matrix output. Pin 7 is the matrix reset which after proper shaping becomes the reference frequency output at pin 13.

Frequency selection is accomplished by connecting one of the matrix outputs to the reset (pin 7) through frame rate selector switch S8. After the necessary number of pulses have occurred, the selected matrix goes high and resets the binary divider to all zeros. Oscillator waveforms are shown in figure 4-2. The 30-kHz squarewave test point at U1 pin 8 may also be used for checking the accuracy of the referenced oscillator as follows:

	COUNT	PERIOD
High	30,000.9	33.323336 usec
Nom	30,000.0	33.333333 usec
Low	29,999.1	33.334333 usec

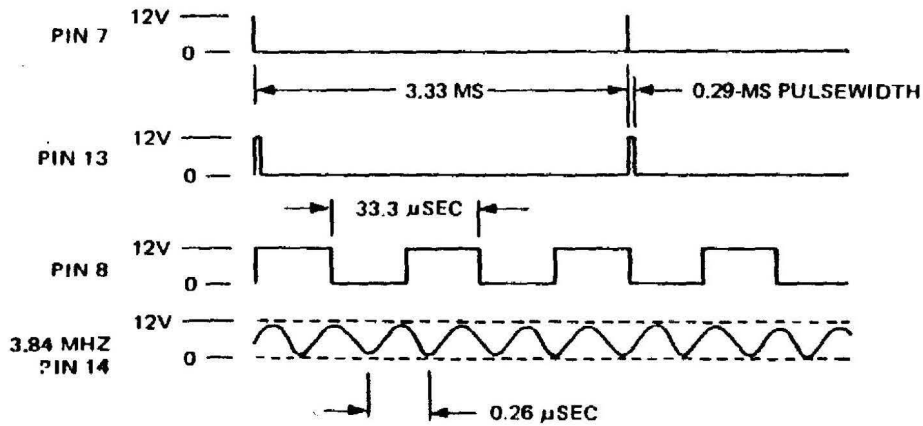

Figure 4-2. Reference Oscillator Waveforms for 24 FPS

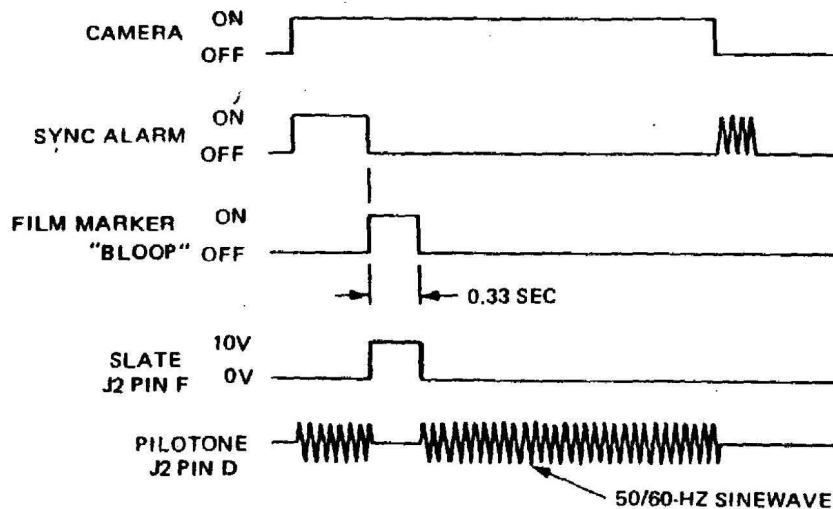

Figure 4-3. Pilot/Slate Sequence

PILOTONE, CLAP, BLOOP CIRCUIT. Hybrid integrated circuit U5 produces a 50- or 60-Hz sinewave as selected by 50/60 pilot frequency switch S1. The pilotone signal has an amplitude of approximately 1 volt rms into a 1,000-ohm load at all times while the camera is running. This signal, available at the accessory connector, is used for control of a sound recorder.

Synchronizing the sound recorder and the film in the camera is accomplished by sinewave interruption, +10v slate, and film fogging as shown in figure 4-3. Film fogging is accomplished by turning on bloop lamp DS1. Slate and film marker lamp are enabled only when there is a resistive load of 27K ohms or less at the output of U5 pin 10. This load is usually the input to the sound recorder's pilotone circuit.

The bloop lamp driver is a three-stage Darlington emitter-follower. At the proper time in the slate sequence, pin 14 of U5 goes high, turning on the driver. The output voltage is limited to 7 volts by regulator U8. Pin 3 of U8 senses the output voltage of Q2. At 7 volts, pin 2 of U8 starts pulling the base of transistor Q1 toward ground, thus limiting any further increase. The output of Q2 drives bloop lamp DS1, which is located in the lens mount area, to fog the film.

PHASE COMPARATOR. Phase comparator or discriminator U3 receives the motor tachometer signal and a reference frequency from the reference oscillator (by way of control logic U2). These two inputs are compared to produce the motor command which is applied to pulsewidth modulator U4. The reference frequency waveform at the FREQ. test point is shown in figure 4-4 and varies with the frame rate of the camera as follows:

FPS	FREQUENCY
12	150 Hz
16	200 Hz
24	300 Hz
25	312.5 Hz
32	400 Hz
48	600 Hz
64	800 Hz

The waveform at the PHASE test point is shown in figure 4-5. The sync alarm ("S" in viewfinder) trips as shown in figure 4-5. The tachometer signal applied to the phase comparator is shown in figure 4-6. One pulse occurs for each hole in the tach disc (5 pulses per revolution).

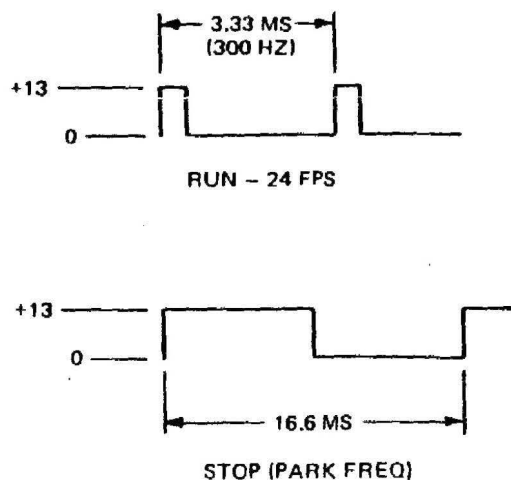

Figure 4-4. Reference Frequency for Phase Discriminator

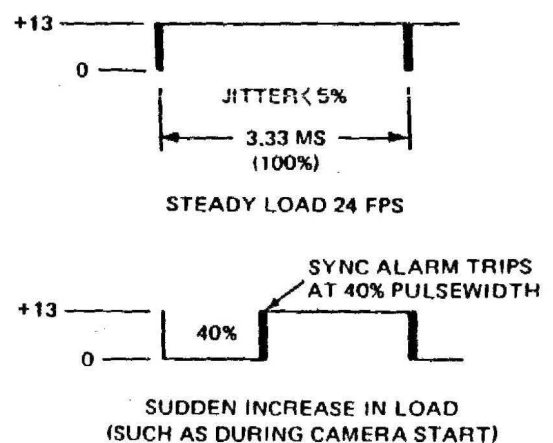

Figure 4-5. Phase-Lock Test Point

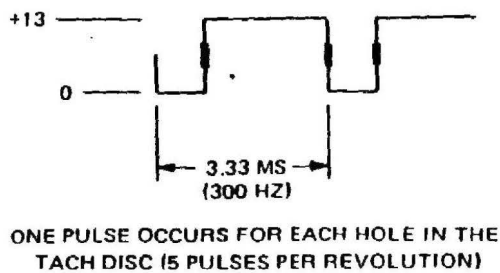

Figure 4-6. Tachometer Signal

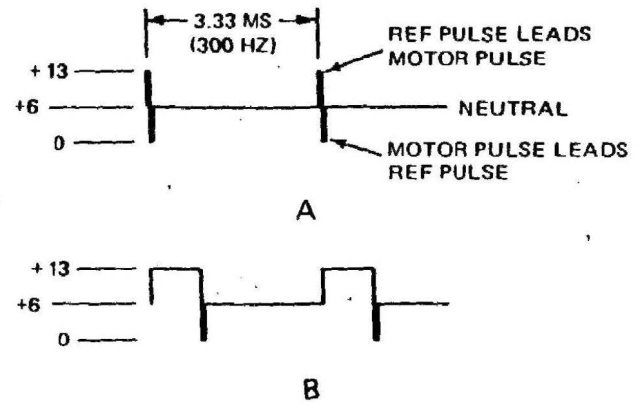

Figure 4-7. Motor Command From Phase Discriminator

The motor command from the phase discriminator can be checked at the motor command test point and is shown in figure 4-7A. During normal operation at 24 fps, the net result is an analog dc level of approximately 6 volts. When the camera could slow because of an increasing load, the reference pulse begins to lead the motor pulse and the test point will appear as shown in figure 4-7B. Because the upper pulse is now wider, the analog dc level will be greater than the neutral +6 volts, thus causing pulsewidth modulator U4 to give more power to the motor.

More power to the motor results in the tachometer pulse catching up with the reference pulse until a balance is reached between camera load and phase error. Once the camera system settles down under the new load, the waveform at the test point will again look like that shown in figure 4-7A.

PULSEWIDTH MODULATOR. Pulsewidth modulator integrated circuit U4 receives the motor command from the phase comparator and a 30-kHz sawtooth at U4 pin 12 and produces the variable pulsewidth motor command which is applied to drive amplifier printed circuit assembly Z79-0329. The output of the pulsewidth modulator is shown in figure 4-8.

OVERLOAD SHUTDOWN. Motor drive pulses from pin 4 of U4 are fed to pin 7 of control logic circuit U2. These pulses continuously reset an internal RC timing network which holds the output low at pin 2 (overload shutdown). At 100-percent motor drive, there are no longer any pulses for resetting the RC network, which takes 0.3 to 0.5 second to charge to the trip point. The output at pin 2 goes high, clamping the motor off and holding pin 4 of U4 high, thus latching the camera system. The latch can be cleared by removing the battery pack, then replacing it.

CONTROL LOGIC. With switched B+ high (RUN/STOP switch S4 in RUN), the primary purpose of control logic integrated hybrid circuit U2 is to monitor the motor load as described above and select the reference frequency for the phase comparator. Normally the reference oscillator signal is passed through unless a signal appears at pin 6. This external signal has priority over pin 3 (REFERENCE OSCILLATOR).

When switched B+ is low at pin 14 (S4 in STOP position), U2 produces a 60-Hz squarewave as reference to slow the camera to 5 fps. The moment pin 1 (SHUTTER POSITION) goes low, pin 11 goes high to stop the motor. At the same time, pin 4 (POWER SUPPLY LATCH) is timing out so that after 1 to 2 seconds it goes low, turning off the regulator and main board. U2 is then kept on for another half second by the charged capacitor at pin 10. The whole system is then shut down.

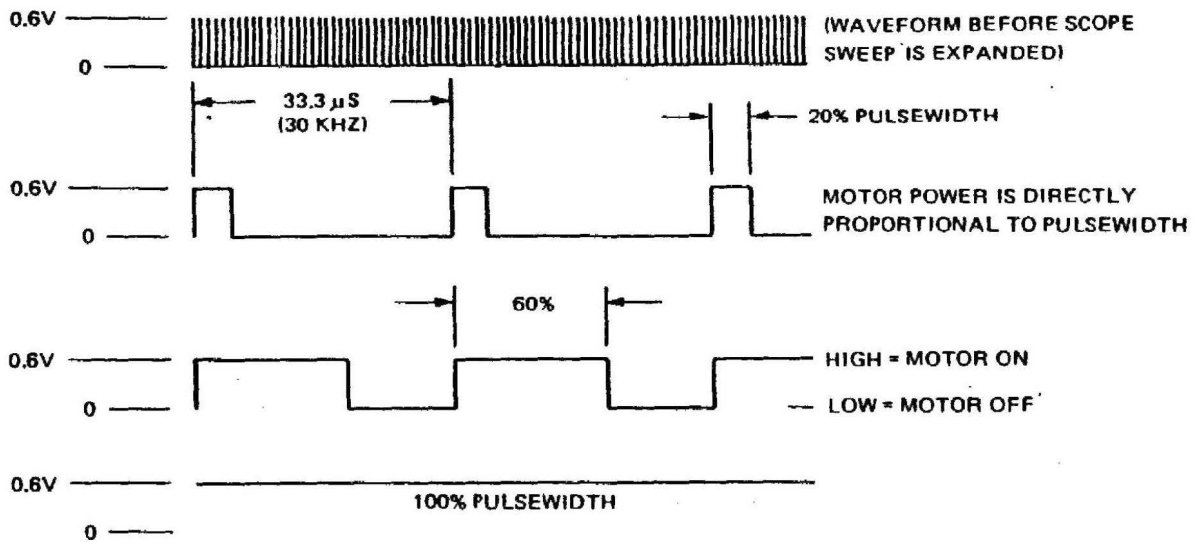

Figure 4-8. Pulsewidth Modulator Output

ACCELERATION AND RESET. Transistors Q5 and Q6 make up the acceleration and reset circuit. Acceleration control is accomplished by the charging of capacitor C6 at the base of Q5. Q5 acts as an emitter-follower that tracks the rising voltage across C6. The rising voltage at pin 7 of pulsewidth modulator U4 slowly enables U4 until full power is available to the motor.

Reset is accomplished any time the +13v line is at 0 volts (as when the camera is first turned on or when the shutter is closed during the "park" sequence with the RUN/STOP switch in STOP). During the "park" sequence when the shutter closes, pin 11 of U2 goes to +13v. This turns on Q6 to clamp the motor off via pin 6 of U4 and at the same time discharge C6, thus resetting the acceleration circuit.

POWER SUPPLY. Power supply hybrid circuit U6 is a strobable regulator with a 60-ma output at pin 1 buffered by Q12. The emitter of Q12 is fed to pin 7 of U6 and to the camera electronics.

When RUN/STOP switch S4 is set to RUN, pin 5 of U6 goes high, enabling the regulator to provide +13 volts. Pin 4 of control logic U2 goes high to latch the regulator on.

Setting the RUN/STOP switch to STOP causes the electronics to go through the "park" sequence: switched B+ (pin 5 of U6) is low, pin 4 of U2 continues to hold the regulator on until the shutter closes. At this time, pin 4 of U2 goes low, disabling the regulator and shutting down the electronics.

Overload protection is provided by resistor R28 (100 ohms) connected to the collector of Q12. A short circuit will burn out this resistor.

SEMI-AUTOMATIC AND FULLY AUTOMATIC EXPOSURE CONTROL SYSTEMS

SYSTEM DESCRIPTION. The semiautomatic and fully automatic exposure control systems consist of three circuit board assemblies and a supplementary wiring harness as shown in figure 6-7. Exposure control can be installed in GSMD camera bodies with serial number 116 and higher.

The fully automatic system includes the semiautomatic system with a motor cable and servomotor to control the lens iris. The motor has a switch disabling the fully automatic system for reverting to semiautomatic operation.

ASSEMBLY DESCRIPTION. Photodetector assembly Z79-0382 consists of the silicon photo diode CR19, focusing lens, sensitivity weighting baffle and holder. The assembly should not be disassembled but rather always handled as a unit. Do not loosen the red painted screws. The 2-pin connector P6 plugs into J10 of preamplifier and display assembly Z79-0373 (with red striped wire to the right).

Preamplifier and display circuit board Z79-0373 replaces the standard display board assembly Z79-0372 used in nonexposure control cameras. Z79-0373 consists of the photodetector preamplifier integrated circuit U11 and its nulling adjustment, R45. Also located here is film marker lamp DS1 (Z79-0469) and viewfinder display assembly Z79-0355 with decoder/driver integrated circuit U12. See figures 6-9 and 6-10.

Photodetector connector P6 plugs into J10. Camera harness plug P4 connects to J8. Exposure control harness connector P11 plugs into J9. In *fully automatic* systems, front cover cable (Z79-0380) connector P7 plugs into J11. J15 is a test connector.

The camera front cover must be removed to service this assembly. Flange depth *must* be checked after the cover is replaced.

Main exposure control circuit board Z79-0490 contains control hybrid U15, +12volt *system* regulator U14, log converter integrated circuit U16, amplifier null control R61, and calibration control R53. This assembly replaces connector plate assembly Z79-0341 used in nonexposure control cameras.

THEORY OF OPERATION. (See figure 4-9.) Twenty percent of the viewfinder light is diverted to photo diode CR19 by a cube beamsplitter Z79-0439. Light striking the photo diode causes the current through the diode to change linearly. When the light striking the photo diode is doubled (increased one stop), the current doubles. Likewise when the light is reduced by half (decreased one stop), the current is halved. U11 is a current amplifier referenced to the +6 volt reference line through R44. Voltage developed across the cell due to a change of light is canceled by feedback through R43. Therefore, the preamplifier is very accurate and insensitive to temperature variations. If the photo diode is unplugged, the voltage *across* test socket J15 will be 0.00000 volt. The output voltage of U11 pin 6 changes linearly with light.

The preamplifier output signal is fed to log converter circuit U16A and associated circuitry inside U15. The logarithmic characteristic of the emitter-base junction of a transistor is the feedback element, causing U15 pin 9 to yield a logarithmic output. The voltage at U15 pin 9 uniformly increases (or decreases) by 24 mV for every stop of increasing (or decreasing) light. Example: If light is increased by two stops, then pin 9 increases by 48 mV.

U16 contains two matched transistors and a thermostatic heater to stabilize the exposure control system within 15 seconds regardless of temperature.

Frame Rate. When the exposure control system is switched on, the camera's crystal speed reference oscillator U11 programs the exposure control to compensate for frame rate. The reference signal enters on pin 11 of U15 and is log converted to a voltage at pin 3 of U15 equal to 240 mV for each equivalent "stop" of frame rate change. At 24 fps, this voltage is 1.29 volts *less* than the 6-volt reference line. This voltage is connected to the summing point through R59.

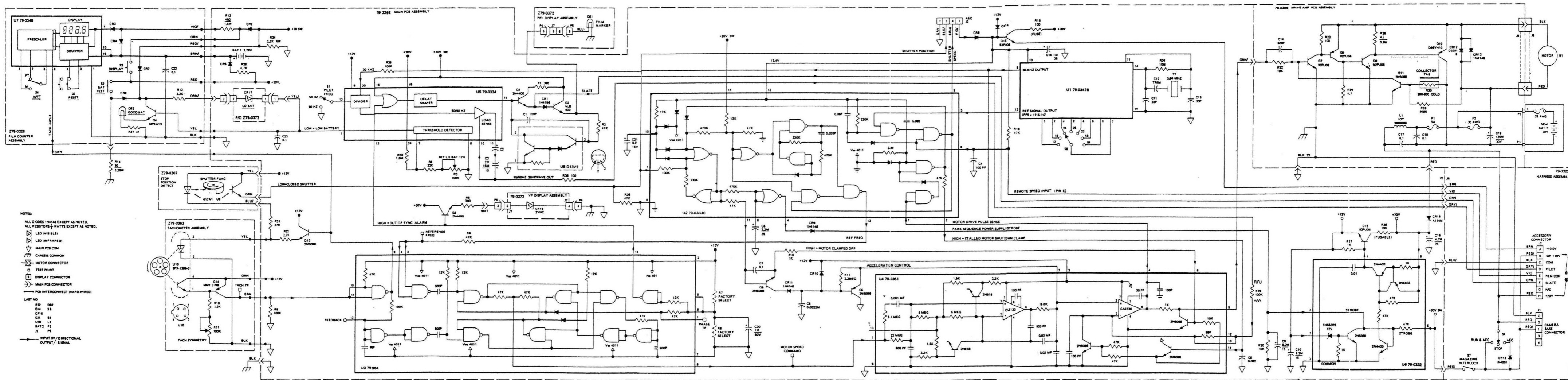

Figure 4-10. GSMO Camera, Schematic Diagram

Film Speed. Potentiometer R48 is a calibrated user-adjustable control which programs the exposure control system to the type of film being used. Knobs are available in ASA or DIN units. The wiper arm of R48 gives 2 volts per stop in change of film speed (i.e., 50 to 100 or 200 to 100). This voltage is connected to the summing point through R60.

At the summing point, the film speed, camera speed, and system calibration control R53 are combined through summing resistors. Any parameter change equivalent to one stop results in a 24-mV change at the summing point. The net difference between the summing point (U15 pin 1) and light input (U15 pin 4) is amplified by 10 and measured at U15 pin 7 as 240 mV per stop.

The sample-and-hold circuit in U15 allows light measurement during only the viewing part of every mirror/shutter rotation. A low signal on U15 pin 12 indicates the mirror is in the viewing position. The summing amplifier output pin 7 of U15 charges the 0.02-MF capacitor through the FET, storing the exposure data until the next measurement period.

The output of the sample-and-hold amplifier is fed to both the fully automatic system (described later) and the active low-pass network. Due to the extremely fast response to light, the display might flicker when shooting under fluorescent lights *without* a low-pass network. Pin 20 is the output of the low-pass filter and becomes the display command. R61 is adjusted during calibration.

Display decoder hybrid U12 is a resistive divider with eight voltage comparators. The voltage from U15 pin 20 is compared to the resistive divider and the appropriate LED is lit. Any time CR24, the "0" LED, is *not* on alone, pin 12 of U12 goes high to activate the iris servomotor.

Iris Motor Control. The iris motor in the fully automatic system receives an error signal from U15 pin 17 on motor pin E. Comparison to the 6-volt reference line at motor pin D determines the rotation to correct the exposure. The motor common returns through motor pin C to display assembly Z70-0373, where it is controlled by FET switching transistor Q17. When the viewfinder display shows "0," Q17 cuts power to the motor to conserve battery power. Q16 clamps Q17 off during film marking to cut off motor power, preventing unnecessary iris changes due to light from film marker lamp DS1.

SECTION 5 – MAINTENANCE

GENERAL

This section describes periodic maintenance and adjustment procedures for the GSMO camera. The camera has been designed to minimize maintenance requirements.

CLEANING. Each time the camera is loaded with film, check the magazine and film gate assembly for bits of film, dust, or other foreign matter. Clean with a lens brush and dry air as necessary. Protect the camera from dust and dirt whenever possible.

LUBRICATION. No periodic lubrication is required. The camera contains bearings which are permanently lubricated at the factory.

ELECTRONIC ADJUSTMENTS

AUTOMATIC EXPOSURE CONTROL. Calibration of the automatic exposure control system should not be required unless components are replaced. If calibration is required, use the following equipment, or equivalent:

- a. Light source — 125 foot-lambert
- b. Digital voltmeter capable of reading 0.000001 vdc
- c. Well-calibrated lens
- d. Fully charged NC-4 battery

Proceed as follows:

1. Disconnect P6 from J10 on the preamplifier and display board.
2. Connect DVM to J15. Polarity is not important.
3. Power up camera in AEC position of S4. Allow 1 minute for full warmup.
4. Measure voltage. It should be 0.000000 ± 0.000002 volt. If necessary, adjust R45 for specified voltage. Use a drop of paint to seal R45. Note this requires removing camera front cover. Flange depth must be checked after cover is replaced.
5. Reconnect P6 into J10. Striped wire is to the right.
6. Remove camera side cover. Connect battery or other power to camera. Observe polarity. Switch AEC on. Install lens. Wait 1 minute. Close VF dowsers.
7. Connect DVM to pins 1 and 2 of J16 on Z79-0490.
8. Point lens into 125 foot-lambert light source. Set ASA to 50 or DIN to 18. Be sure camera is set to 24 fps. Adjust lens for 0.000-volt reading.
9. Connect DVM to pins 2 and 3 of J16. Adjust R61 for 0.000-volt reading. Use paint to seal R61.
10. Set lens to t/5.6. (Be sure camera is set to 24 fps and ASA 50 or DIN 19.)
11. Adjust R53 for 0.000 volt. Use paint to seal R53.
12. Switch S4 to RUN. Observe little or no change in reading. Tolerance is ± 0.005 volt.
13. Turn S4 off. Remove power. Install side cover.
14. Install battery. Switch S4 to AEC or RUN. Wait 1 minute. Be sure ASA is set to 50 (or DIN to 19) and FPS switch is set to 24. Set lens to t5.6.
15. Open dowsers and make sure "0" is on.
16. Switch off S4. Remove battery and lens.

SECTION 6 – ILLUSTRATED PARTS BREAKDOWN

GENERAL

This section illustrates the GSMO camera and its replaceable assemblies and subassemblies. Component parts not shown or identified in this section are not suitable for replacement except at the factory. Do not attempt repair or replacement of any part unless properly trained on this camera and on precision photographic equipment in general. Contact Cinema Products for repair parts and/or assistance in making parts replacements.

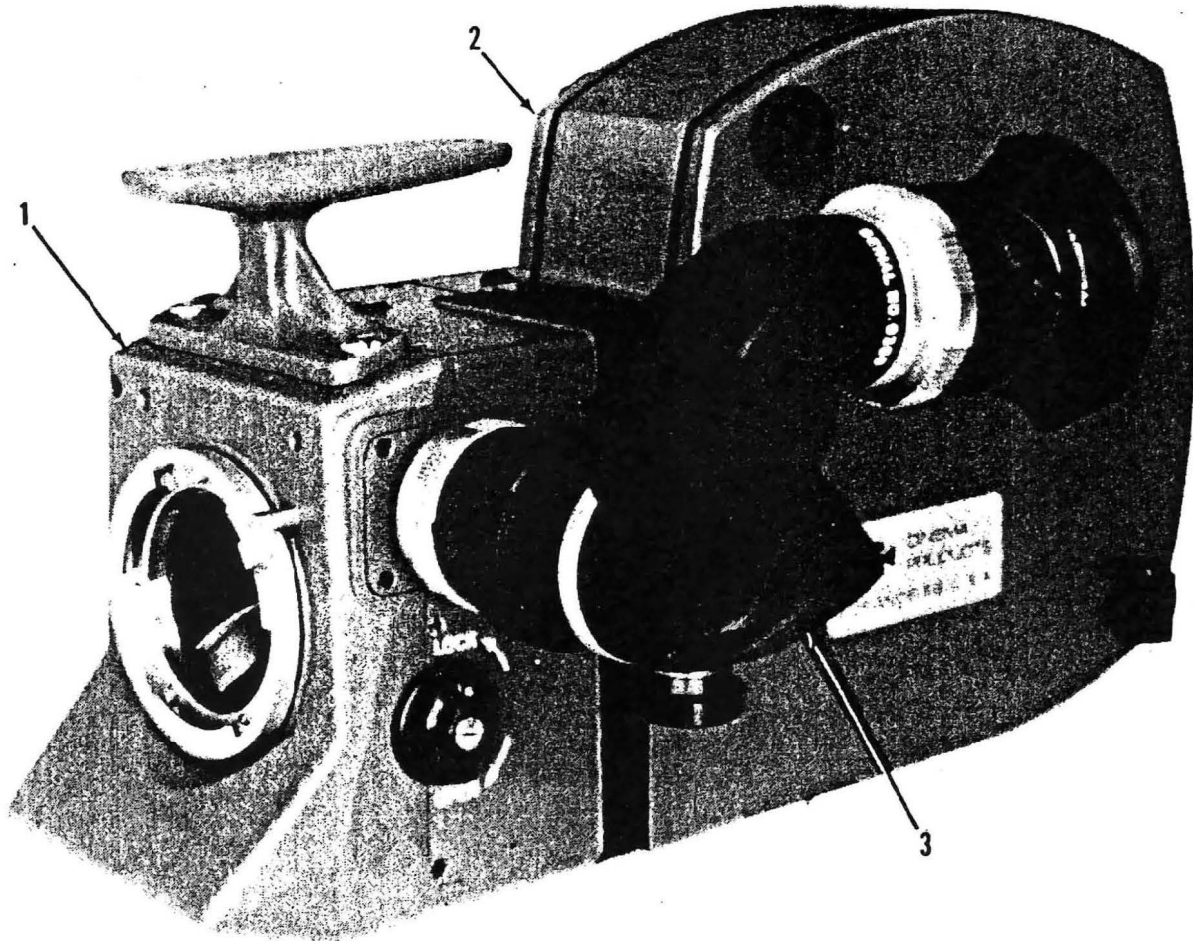

Figure 6-1. GSMO Camera Assembly

Fig. & Index No.	Part No.	Description							Units Per Assy	Reference Designation
		1	2	3	4	5	6	7		
6-1-	79-0000-1	CAMERA ASSY, 16mm GSMO							REF	
-1	79-0000	. CAMERA ASSY, 16 MLC (See figure 6-2 for details)							1	
-2	79-0235	. MAGAZINE ASSY, 400 ft (See figure 6-17 for details)							AR	
-3	110-0700	. VIEWFINDER, Standard (Optional orientable VF shown)							1	

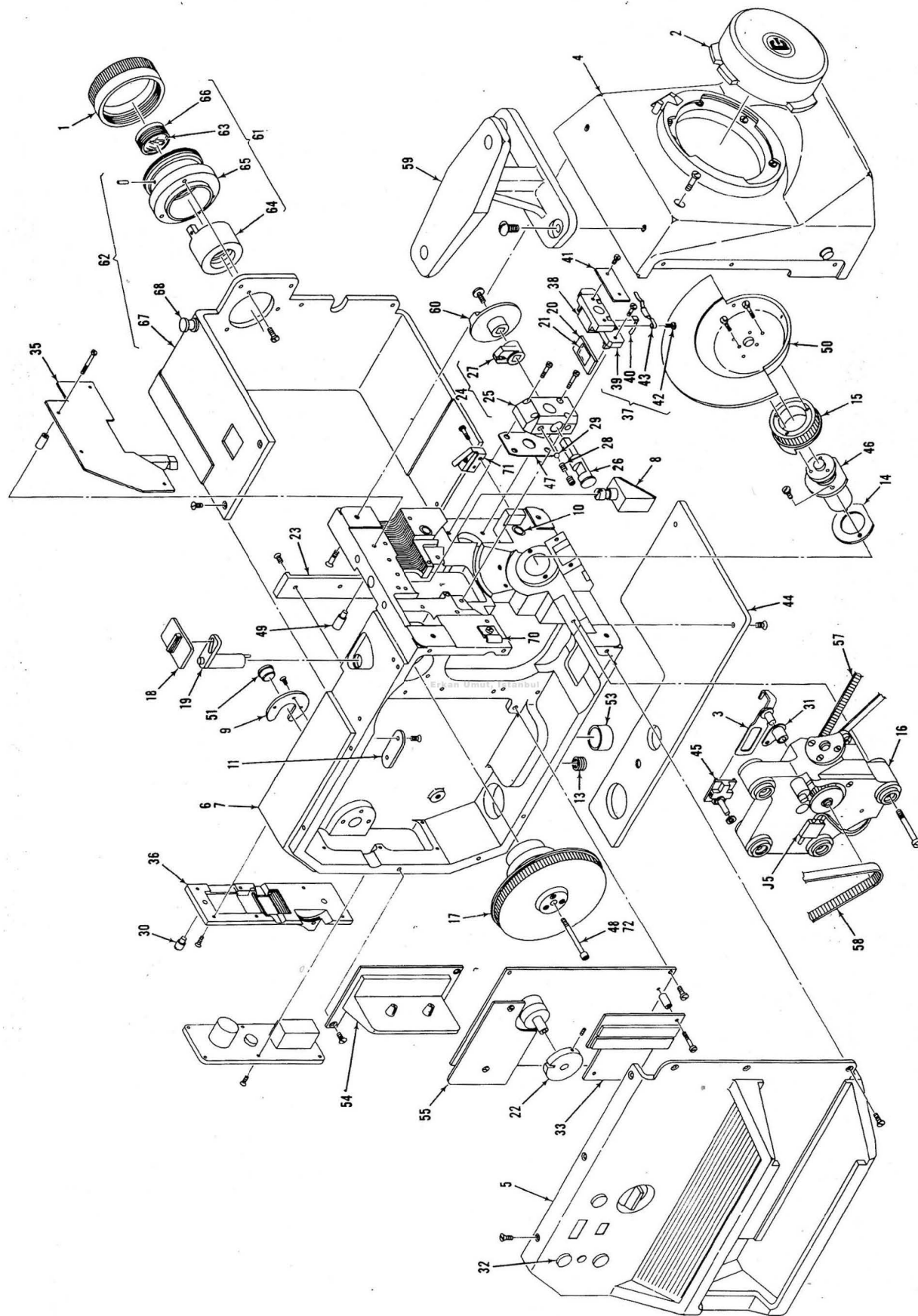

Figure 6-2. Camera Assembly

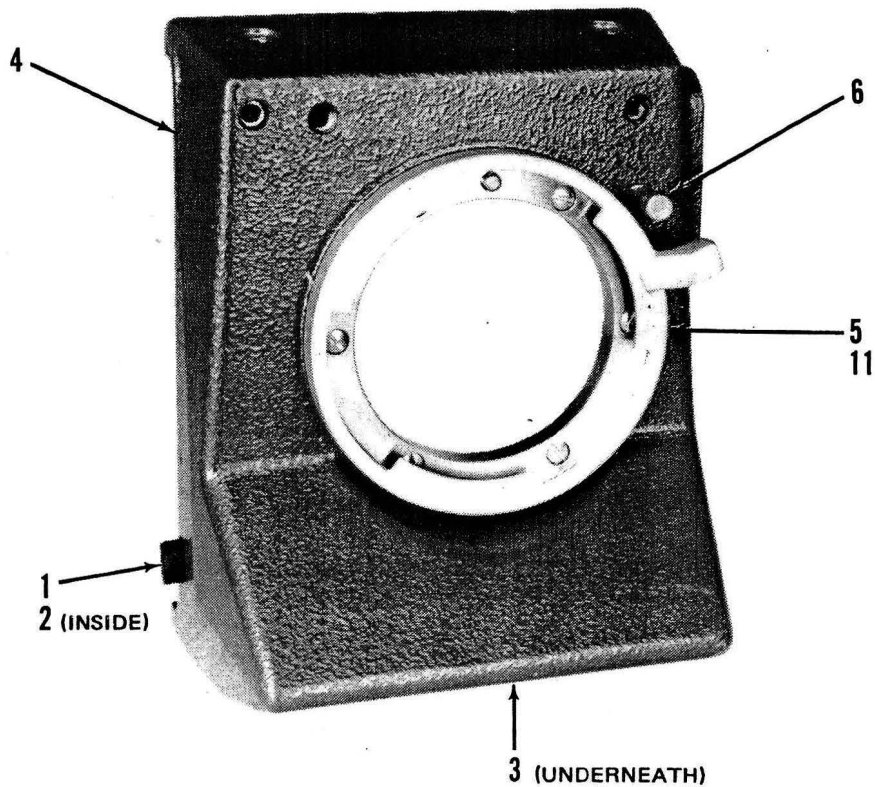

Figure 6-3. Front Cover Assembly

Fig. & Index No.	Part No.	Description							Units Per Assy	Reference Designation
		1	2	3	4	5	6	7		
6-3-	79-0002	COVER ASSY, Front (See figure 6-2 for next higher assembly)							REF	
-1	79-0078	. LATCH, Battery							1	
-2	79-0079	. SPRING, Latch							1	
-3	79-0081	. PLATE, Front cover							1	
-4	79-0103	. COVER, Front							1	
-5	79-0105	. LOCK ASSY							1	
-6	79-0111	. STOP							1	
* -7	79-0283-1	. COVER, Front upper							1	
* -8	79-0283-2	. COVER, Bottom							1	
* -9	79-0283-3	. COVER, Left side							1	
* -10	79-0283-4	. COVER, Right side							1	
-11	79-0110	. SPACER, Lens (machined to size; not supplied as a spare part)							1	

* SOUND DEADING KIT (INSIDE COVER, NOT SHOWN)

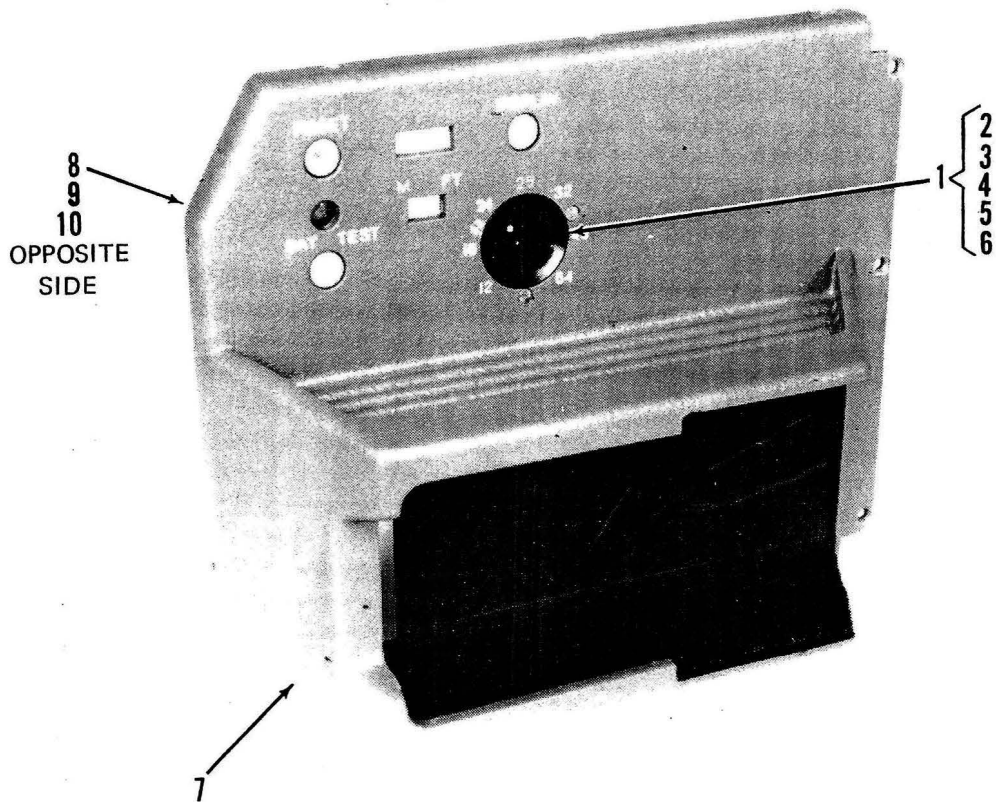

Figure 6-4. Side Cover Assembly

Fig. & Index No.	Part No.	Description							Units Per Assy	Reference Designation
		1	2	3	4	5	6	7		
6-4-	79-0003	SIDE COVER ASSY (See figure 6-2 for next higher assembly)							REF	
-1	79-0086-1	1	
-2	79-0083	1	
-3	79-0085	1	
-4	79-0086	1	
-5	SPG-073965	1	
-6	BAL-084450	1	
-7	79-0112	1	
-8	79-0284-1	1	
-9	79-0284-2	1	
-10	79-0554	1	

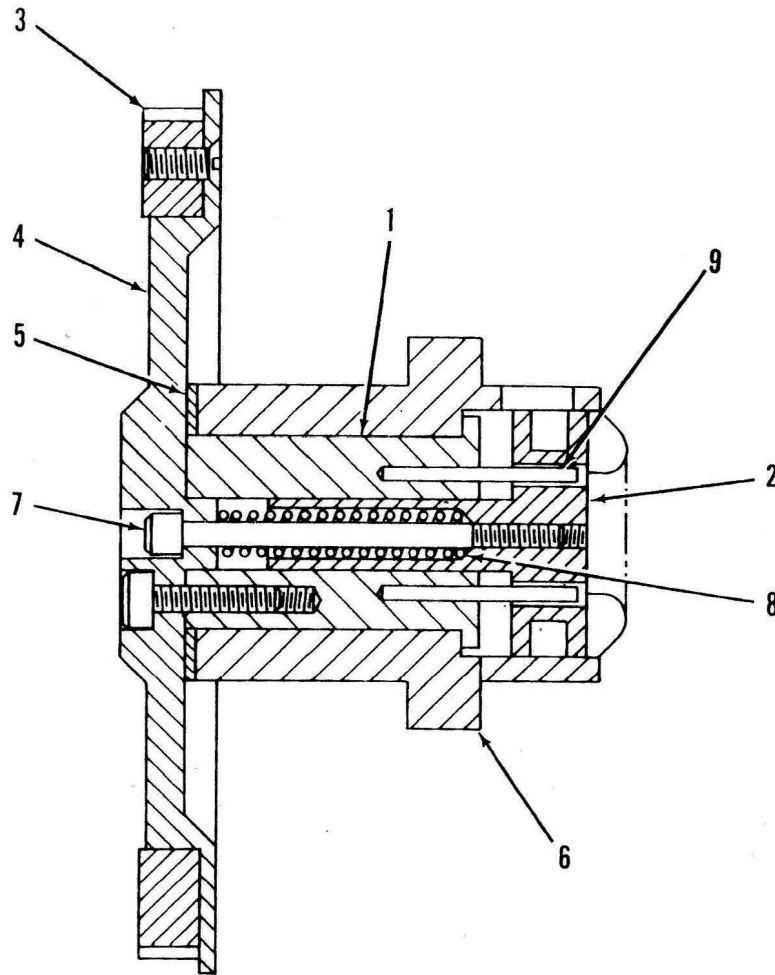

Figure 6-5. Sprocket Drive Assembly

Fig. & Index No.	Part No.	Description	Units Per Assy	Reference Designation
		1 2 3 4 5 6 7		
6-5-	79-0040	SPROCKET DRIVE ASSY (See figure 6-2 for next higher assembly)	REF	
-1	79-0039	. SHAFT, Main	1	
-2	79-0042	. DRIVER	1	
-3	79-0043	. PULLEY	1	
-4	79-0045	. SUPPORT, Pulley	1	
-5	79-0046	. WASHER, Thrust	AR	
-6	79-0047	. BUSHING	1	
-7	79-0293	. SCREW	1	
-8	SPG-076130	. SPRING	1	
-9	STD	. DOWEL, 0.062" x 0.437"	2	

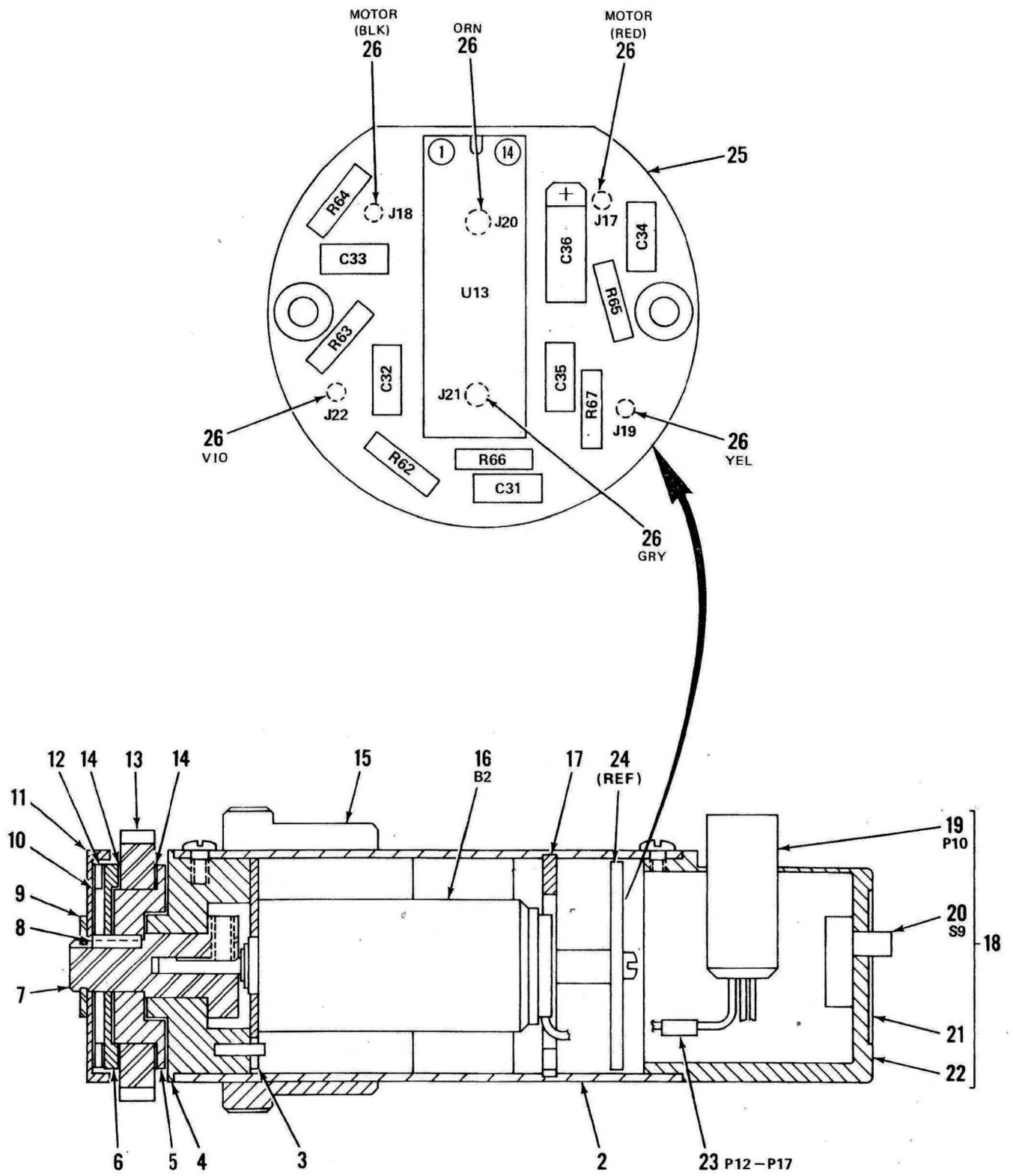
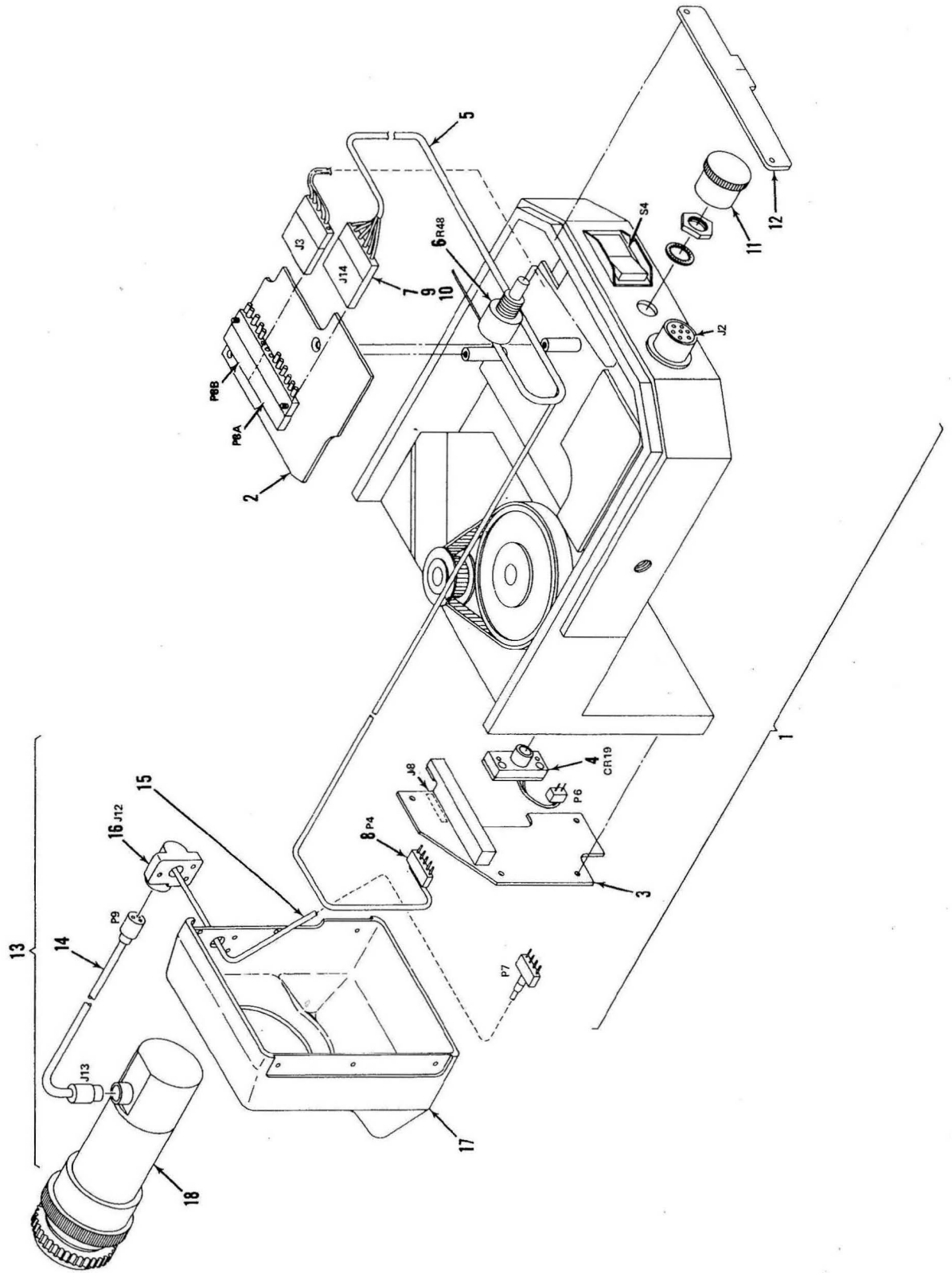

Figure 6-6. Iris Control Motor Z79-0498



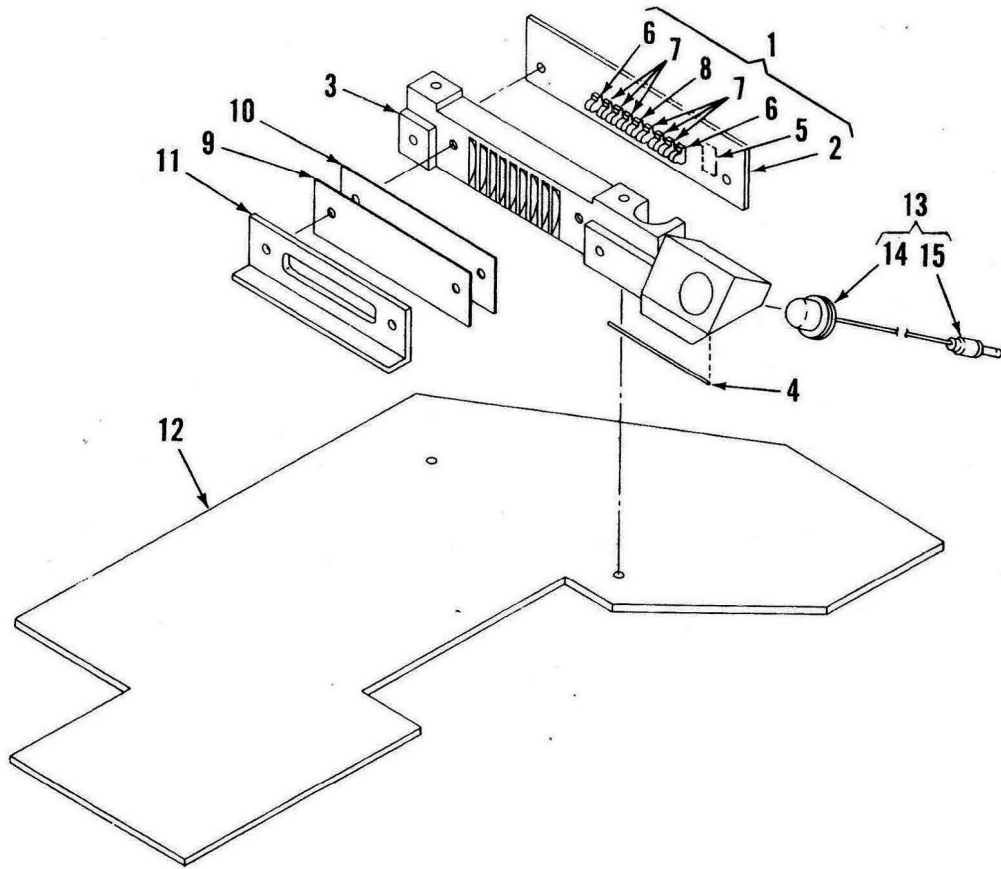
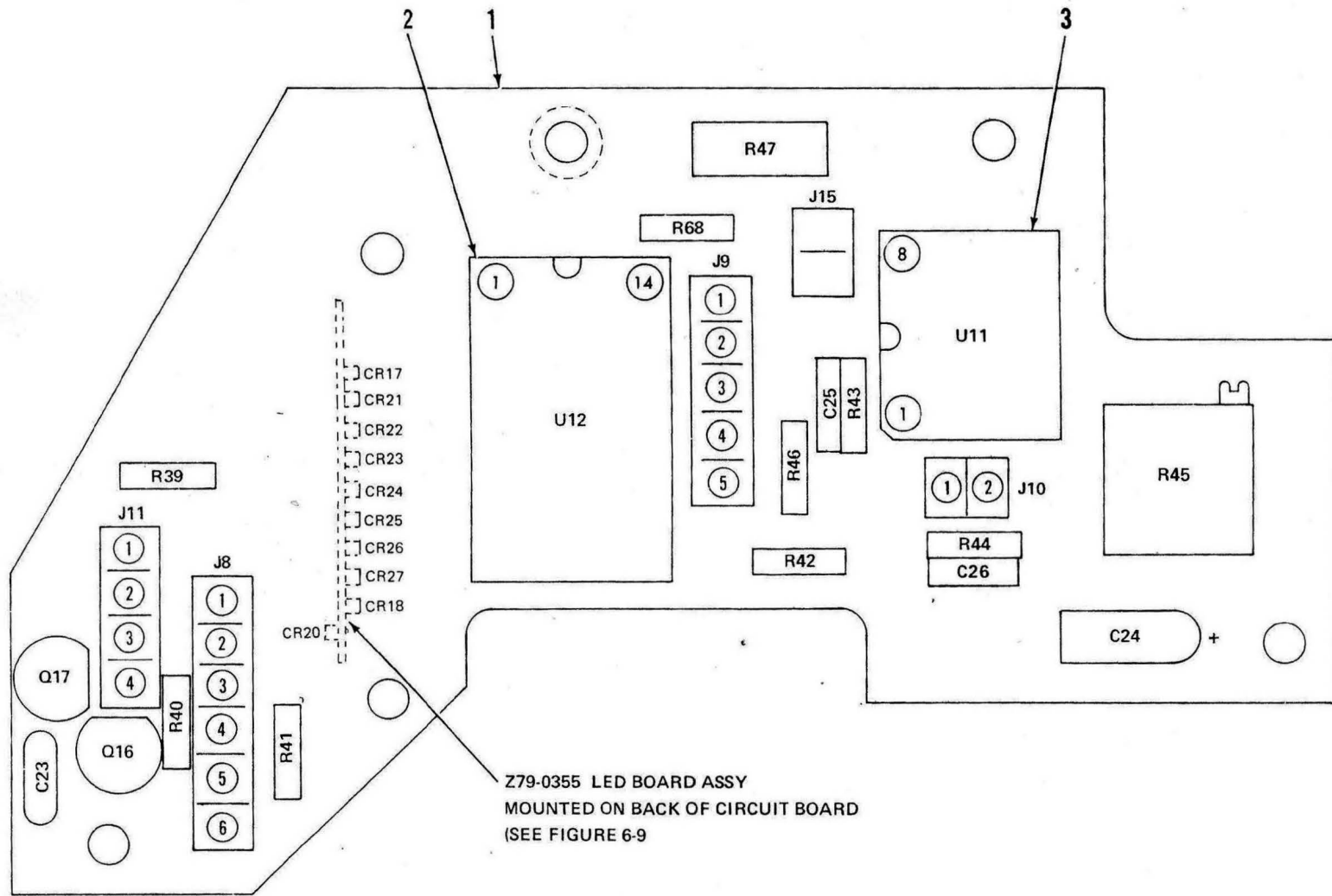

Figure 6-9. Automatic Exposure Control Preamp Amplifier Circuit Board Assembly Z79-0373

Fig. & Index No.	Part No.	Description							Units Per Assy	Reference Designation
		1	2	3	4	5	6	7		
6-9-	Z79-0373	BOARD ASSY, Preamp AEC (See figure 6-7 for next higher assembly)							REF	
-1	Z79-0355	. BOARD ASSY, Light-emitting diode							1	
-2	79-0353	. . BOARD, Circuit LED							1	
-3	79-0440	. . BRACKET							1	
-4	79-0468	. . CONTACT, Wire spring							1	
-5	SMC-063558	. . DIODE, Dual							1	CR20
-6	SMC-063710	. . DIODE, Light-emitting, red							2	CR17,18
-7	SMC-064322	. . DIODE, Light-emitting, yellow							6	CR21-23,25-27
-8	SMC-064345	. . DIODE, Light-emitting, green							1	CR24
-9	79-0358	. MASK							1	
-10	79-0378	. MASK, Diffusion							1	
-11	79-0447	. BRACKET							1	
-12	Z79-0467	. BOARD SUBASSY, Preamp AEC (See figure 6-10 for details)							1	
-13	Z79-0469	. LAMP ASSY, Bloop							1	
-14	LMP-131450	. . LAMP, C443							1	DS1
-15	TML-142305	. . PIN, Terminal							1	P5



C23	0.082 MF	R39	10M	R43	10M	R47	1K
C24	8.2 MF	R40	36K	R44	10M	R68	4.7K
C25	10 PF	R41	36K	R45	20K	Q16	2N4400
C26	10 PF	R42	36K	R46	36K	Q17	VN10KM

Figure 6-10. Automatic Exposure Control Pre-amplifier Circuit Board Subassembly Z79-0467

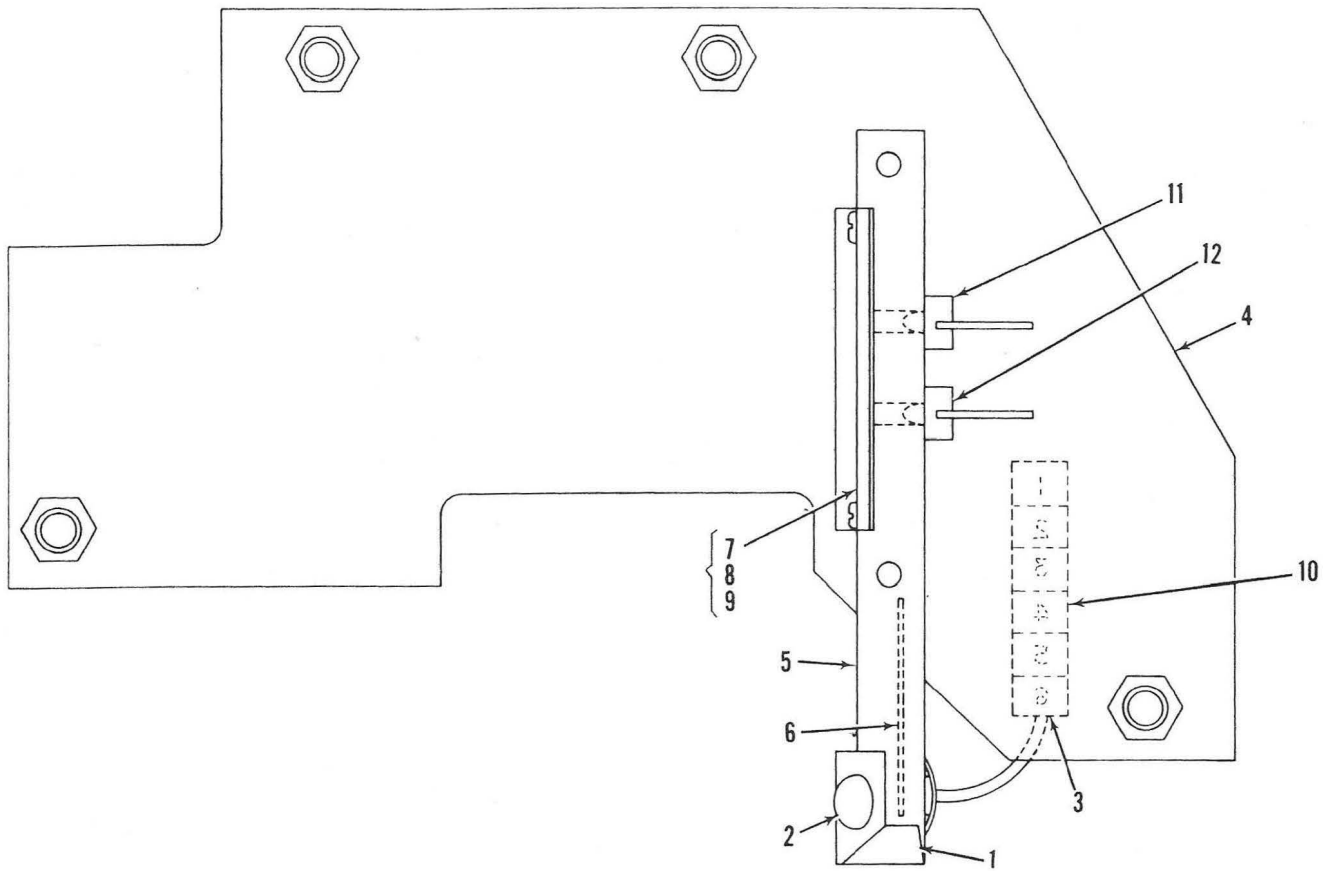

Figure 6-11. Display Board Assembly Z79-0372 (Non-AEC Cameras Only)

Fig. & Index No.	Part No.	Description							Units Per Assy	Reference Designation	
		1	2	3	4	5	6	7			
6-11-	Z79-0372	DISPLAY BOARD ASSY (Non-AEC cameras only) (See figure 6-2 for next higher assembly)							REF		
-1	Z79-0469	. BLOOM LAMP ASSY.							1	DS1	
-2	LMP-131450	. . LAMP							1		
-3	TML-142305	. . PIN, Terminal							1		
-4	79-0371	. BOARD, Printed circuit							1		
-5	79-0376	. BRACKET, LED and bloom							1		
-6	79-0468	. CONTACT, Spring							1		
-7	79-0441	. MASK							1		
-8	79-0447	. BRACKET, Mask							1		
-9	79-0378	. MASK, Diffusion							1		
-10	CON-038546	. CONNECTOR, 6-pin female							1		J7
-11	SMC-063580	. DIODE, Light-emitting, red, "LO BAT"							1		CR17
-12	SMC-063580	. DIODE, Light-emitting, red, "OUT-OF-SYNC"							1		CR18

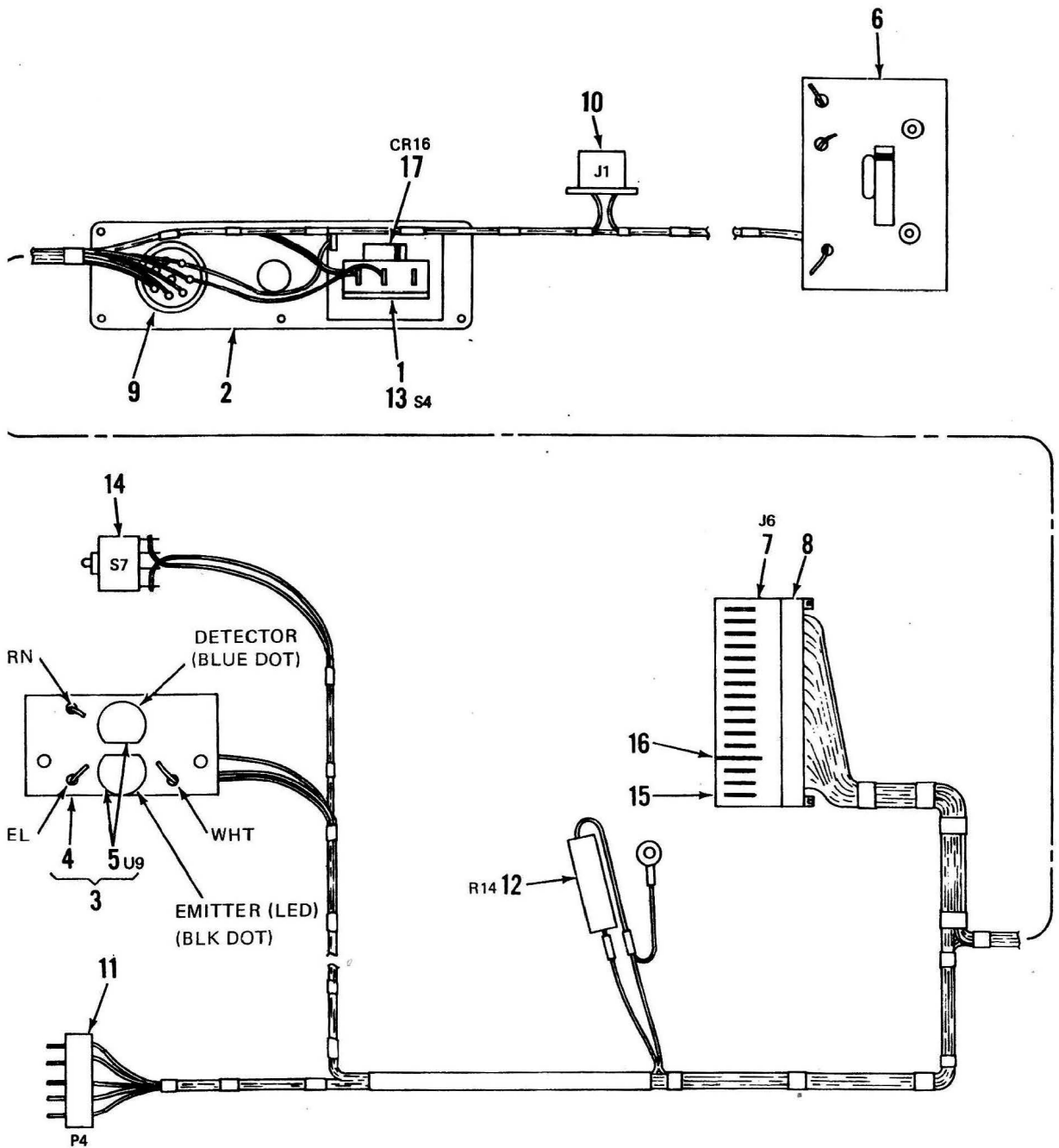

Figure 6-12. Wiring Harness Assembly Z79-0322

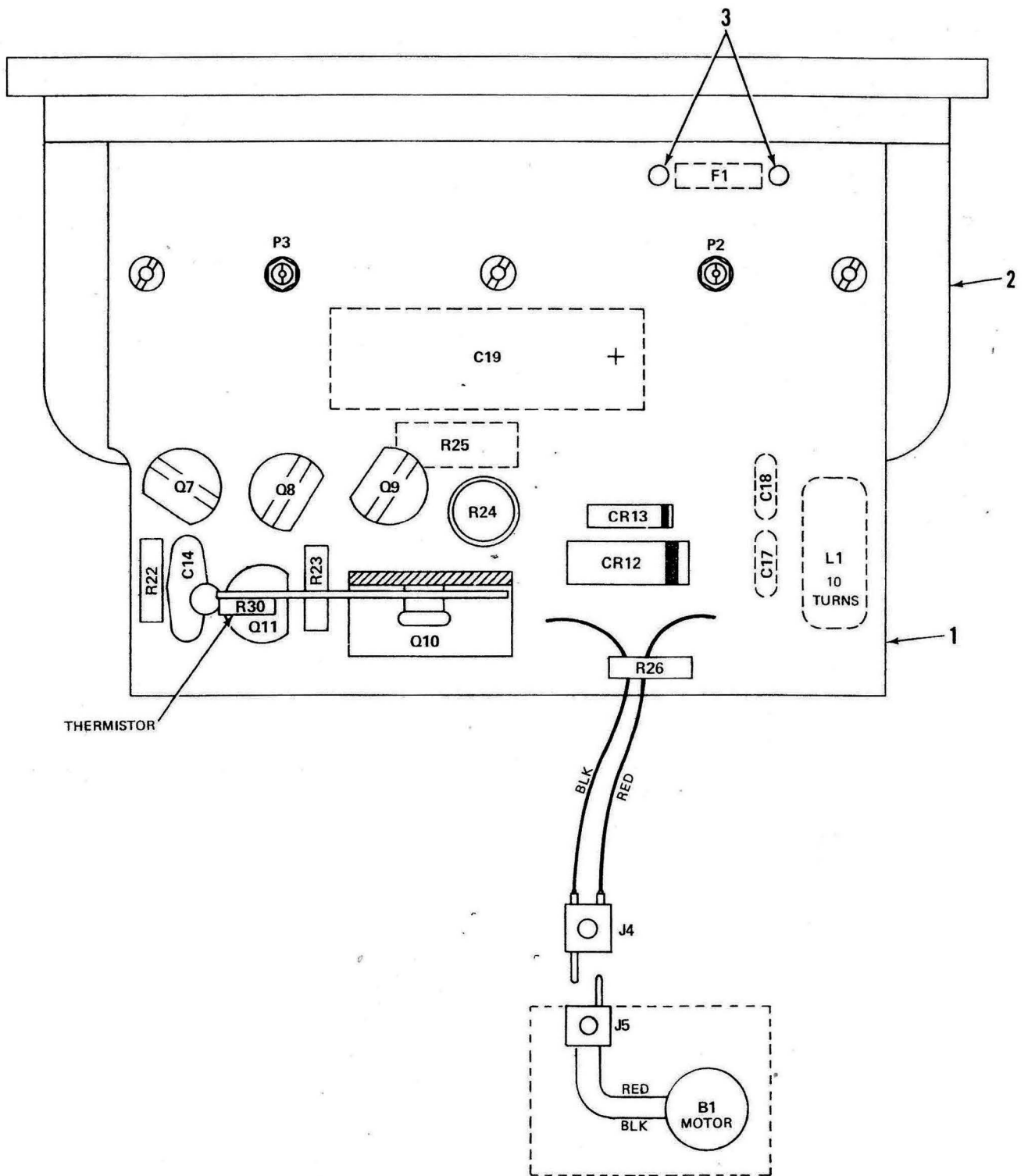

Figure 6-13. Drive Amplifier Assembly Z79-0329

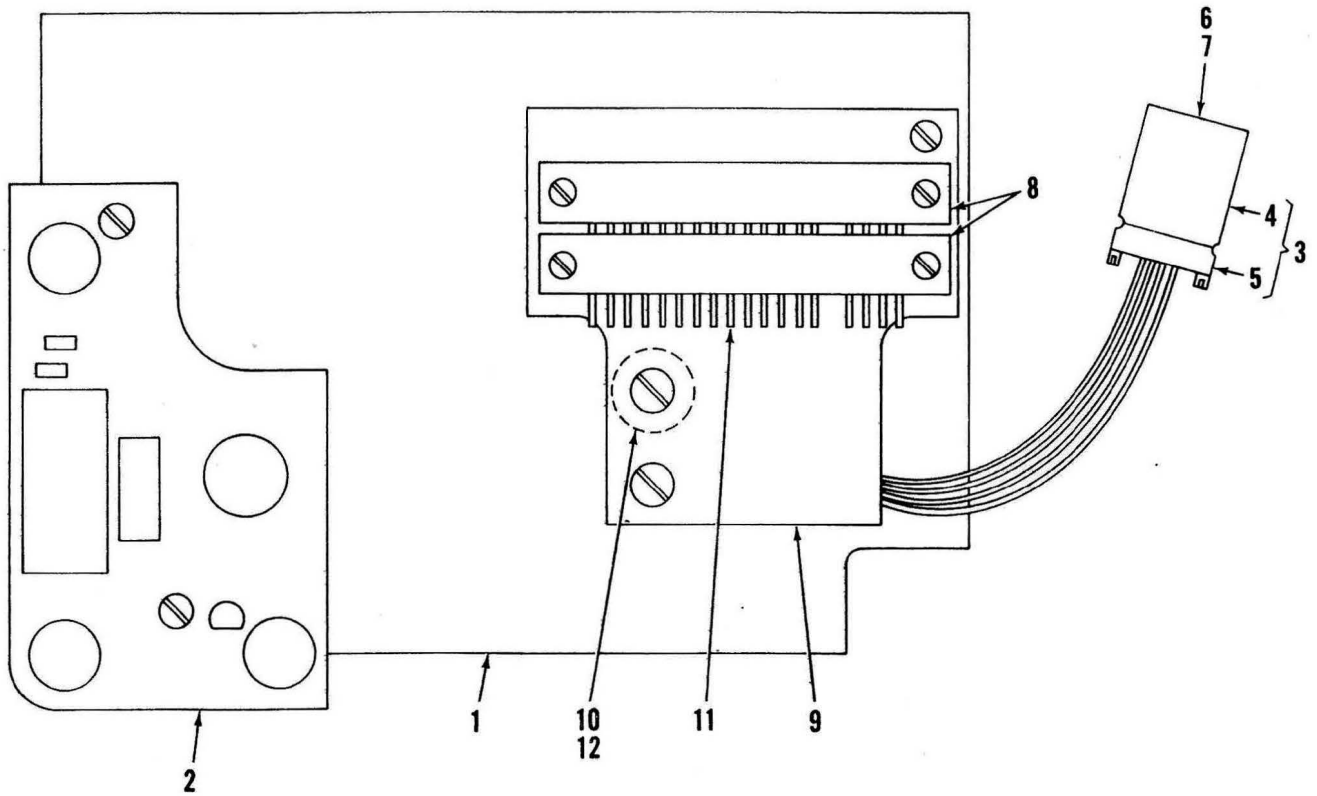

Figure 6-14. Main Control Board Assembly 79-0345

Fig. & Index No.	Part No.	Description							Units Per Assy	Reference Designation
		1	2	3	4	5	6	7		
6-14-	Z79-0345	BOARD ASSY, Main control (See figure 6-2 for next higher assembly)							REF	
-1	Z79-0326	. BOARD ASSY, Control printed circuit (See figure 6-15 for details)							1	
-2	Z79-0328	. BOARD ASSY, Counter printed circuit (See figure 6-16 for details)							1	
-3	Z79-0366	. CONNECTOR ASSY							1	J3
-4	79-0365-1	. . CONNECTOR, Body							1	
-5	79-0365-2	. . GUIDE, Wire							1	
-6	PIN-136001	. . PIN, Connector, male							5	
-7	MSC-150001	. . POST, Polarizing							1	
-8	79-0340-1	. STRIP, Connector (one used as wire guide)							2	P1
-9	79-0341	. PLATE, Connector							1	
-10	HSK-087550	. HEATSINK							1	
-11	PIN-136000	. PIN, Connector							19	
-12	WHR-147140	. WASHER							2	

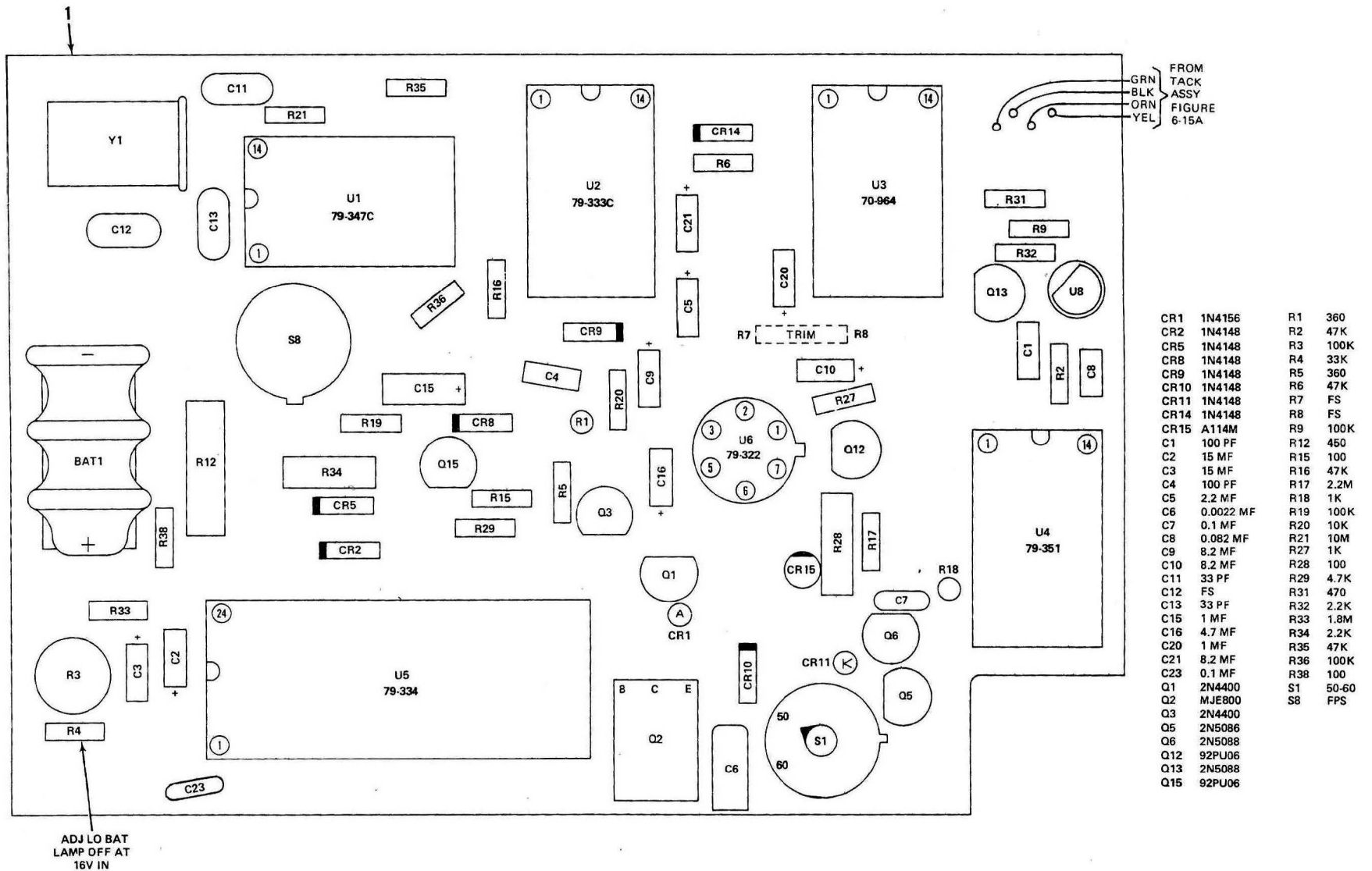

Figure 6-15. Control Printed Circuit Board Assembly Z79-0326 (Sheet 1 of 2)

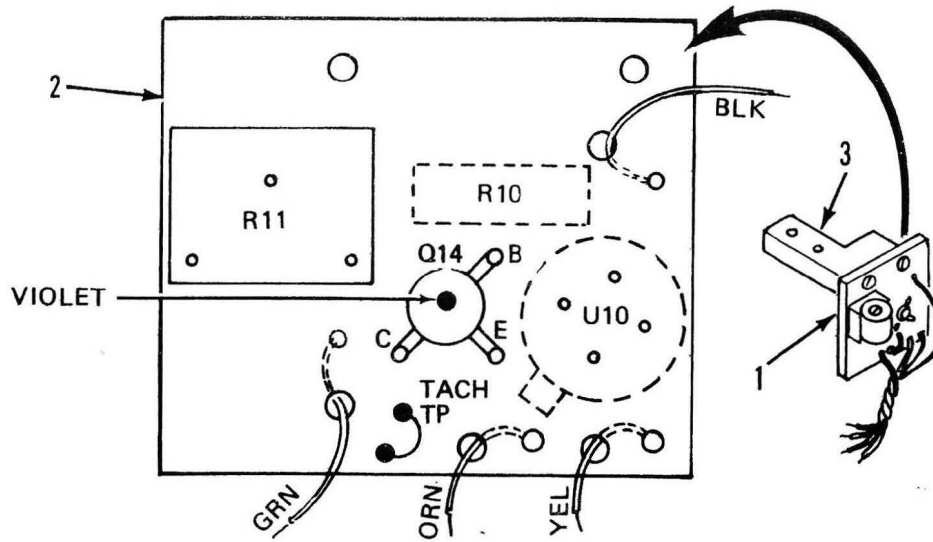

Figure 6-15A. Tach Assembly Z79-0363 (Hard-Wired to Z79-0326)

Fig. & Index No.	Part No.	Description							Units Per Assy	Reference Designation
		1	2	3	4	5	6	7		
6-15-	Z79-0326	BOARD ASSY, Control printed circuit (See figure 6-14 for next higher assembly)							REF	
-1	79-0325	. BOARD, Printed circuit							1	
-2	79-0362	. . BOARD, Printed circuit							1	
-3	79-0364	. . BRACKET							1	
	SCT-138200	. SOCKET, Augut pins for hybrid ICs							100	
	BAT-094400	. BATTERY PACK, 3.75V							1	BAT1
	SMC-064312	. DIODE, 1N4156							1	CR1
	SMC-064200	. DIODE, 1N4148							7	CR2,5,8-11,14
	SMC-063635	. DIODE, A114M							1	CR15
	CAP-017300	. CAPACITOR, 100 PF, 100 vdc							2	C1,C4
	CAP-022650	. CAPACITOR, 1 MF, 50v							1	C20
	CAP-023650	. CAPACITOR, 15 MF, 10 vdc							2	C2,C3
	CAP-022850	. CAPACITOR, 2.2 MF, 25 vdc							1	C5
	CAP-018500	. CAPACITOR, 0.0022 MF, 100 vdc							1	C6
	CAP-021743	. CAPACITOR, 0.1 MF							2	C7,C23
	CAP-021700	. CAPACITOR, 0.082 MF							1	C8
	CAP-023605	. CAPACITOR, 8.2 MF, 15 vdc							3	C9,C10,C21
	N/A	. CAPACITOR, 33 PF, silver mica*							1	C11
	N/A	. CAPACITOR, Factory select silver mica*							1	C12
	N/A	. CAPACITOR, 33 PF silver mica*							1	C13
	CAP-022625	. CAPACITOR, 1 MF, 50 vdc							1	C15
	CAP-023300	. CAPACITOR, 4.7 MF, 25 vdc							1	C16
	SMC-068100	. TRANSISTOR, 2N4400							2	Q1,Q3
	SMC-071000	. TRANSISTOR, MJE800							1	Q2

*Part of 79-0312 kit supplied only as matched set.

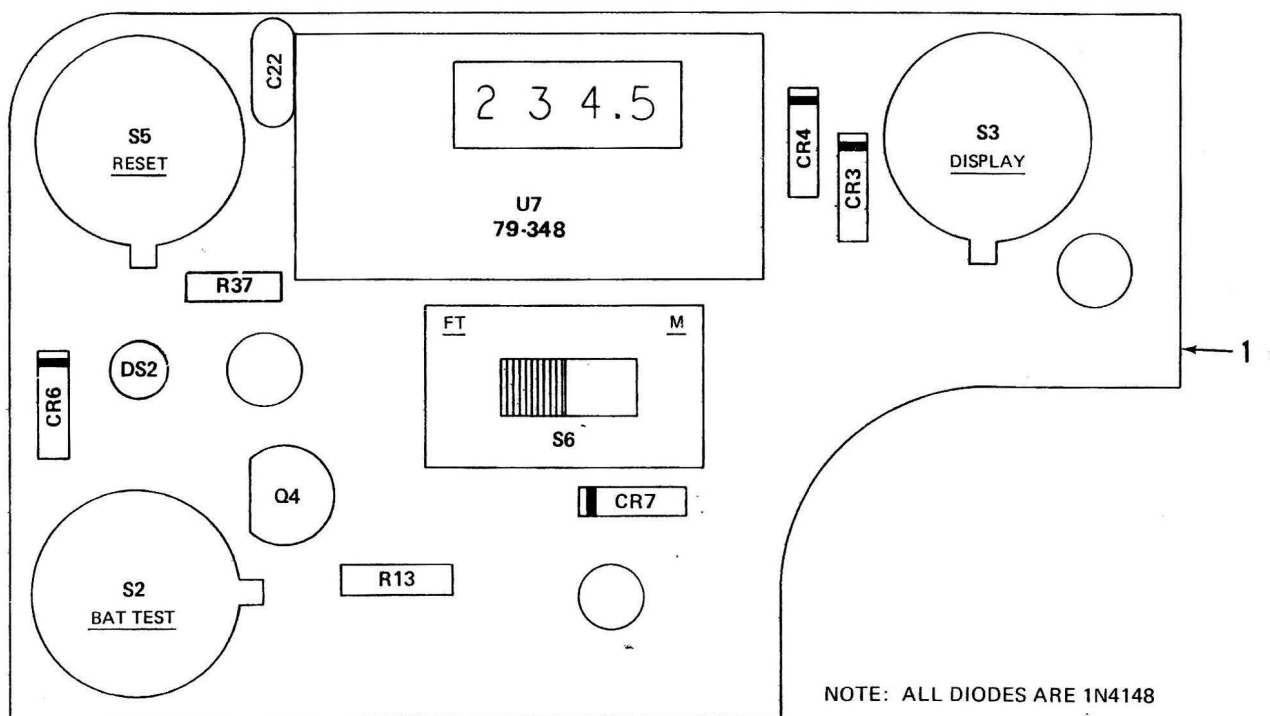

Figure 6-16. Counter Printed Circuit Board Assembly

Fig. & Index No.	Part No.	Description							Units Per Assy	Reference Designation
		1	2	3	4	5	6	7		
6-16-	Z79-0328	BOARD ASSY, Counter printed circuit (See figure 6-14 for next higher assembly)							REF	
-1	79-0327	. BOARD, Printed circuit							1	
	SMC-064200	. DIODE, 1N4148							4	CR3,4,6,7
	CAP-021756	. CAPACITOR, 0.1 MF							1	C22
	LMP-131395	. LAMP, 389							1	DS2
	SMC-061120	. TRANSISTOR, MPS-A13							1	Q4
	RES-051300	. RESISTOR, 3.3K \pm 5%, 1/8W							1	R13
	RES-044450	. RESISTOR, 47 ohms \pm 5%, 1/8W							1	R37
	79-0339	. SWITCH, Pushbutton							3	S2,S3,S5
	SWT-078300	. SWITCH, DPDT, METERS-FEET							1	S6
	79-0348	. CIRCUIT, Integrated hybrid, digital readout							1	U7

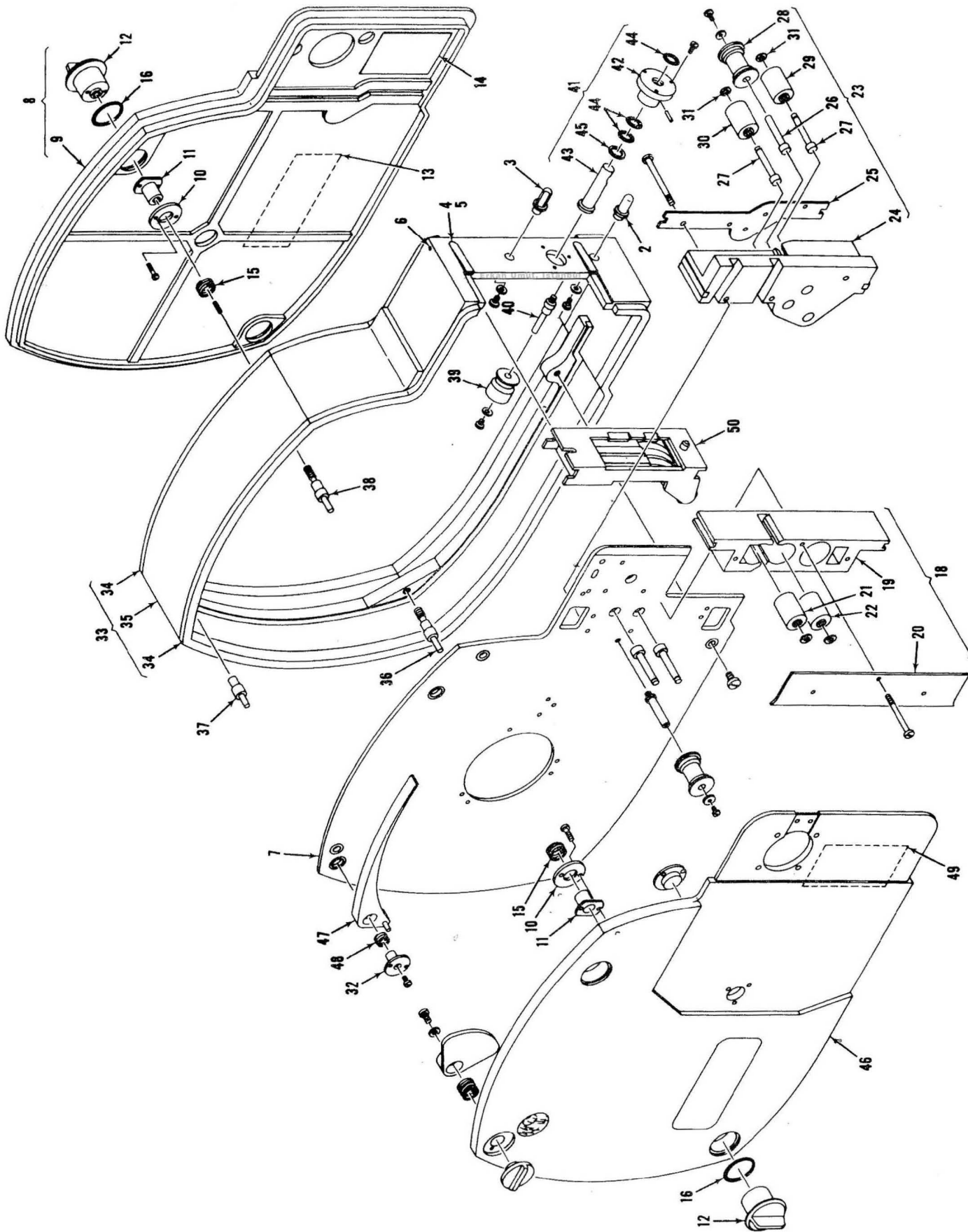

Figure 6-17. 400-Foot Magazine Assembly

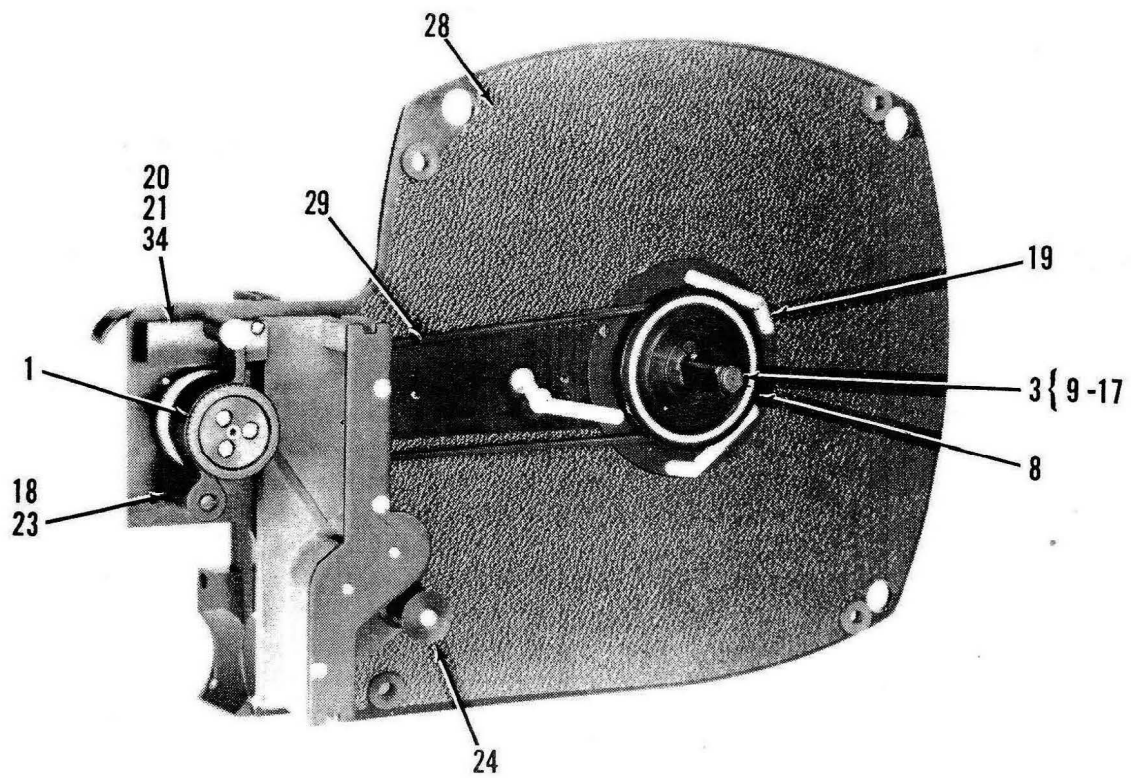
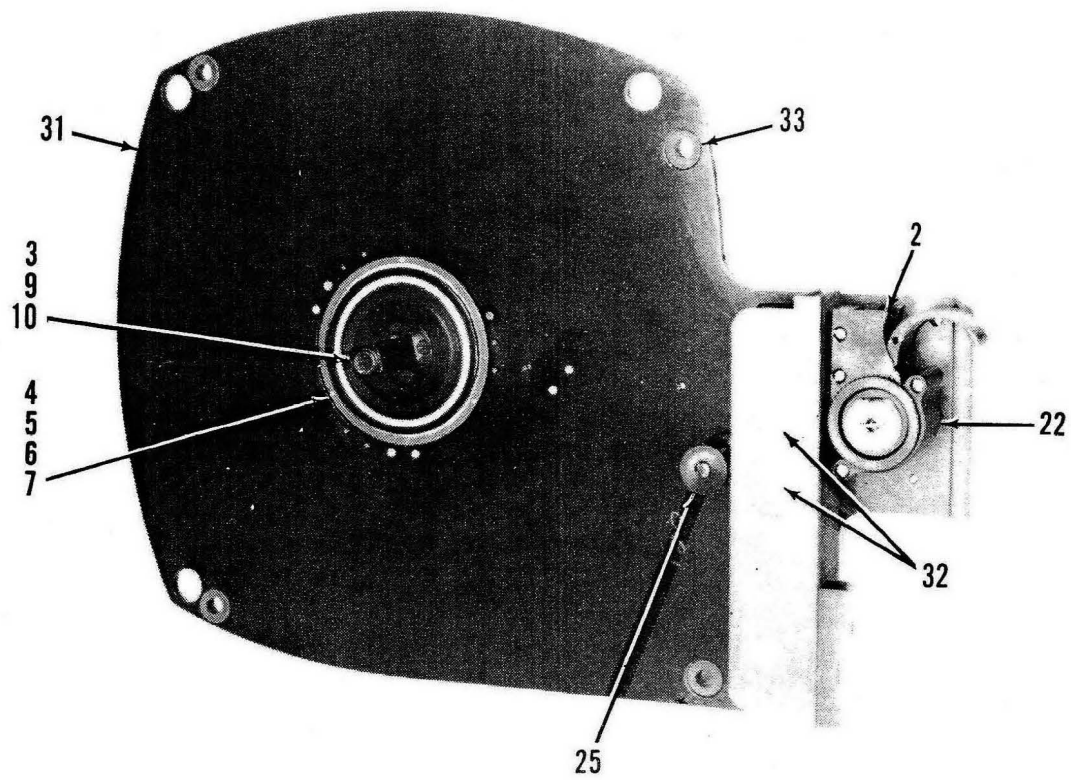

Figure 6-18. Magazine Mid-Rib Assembly

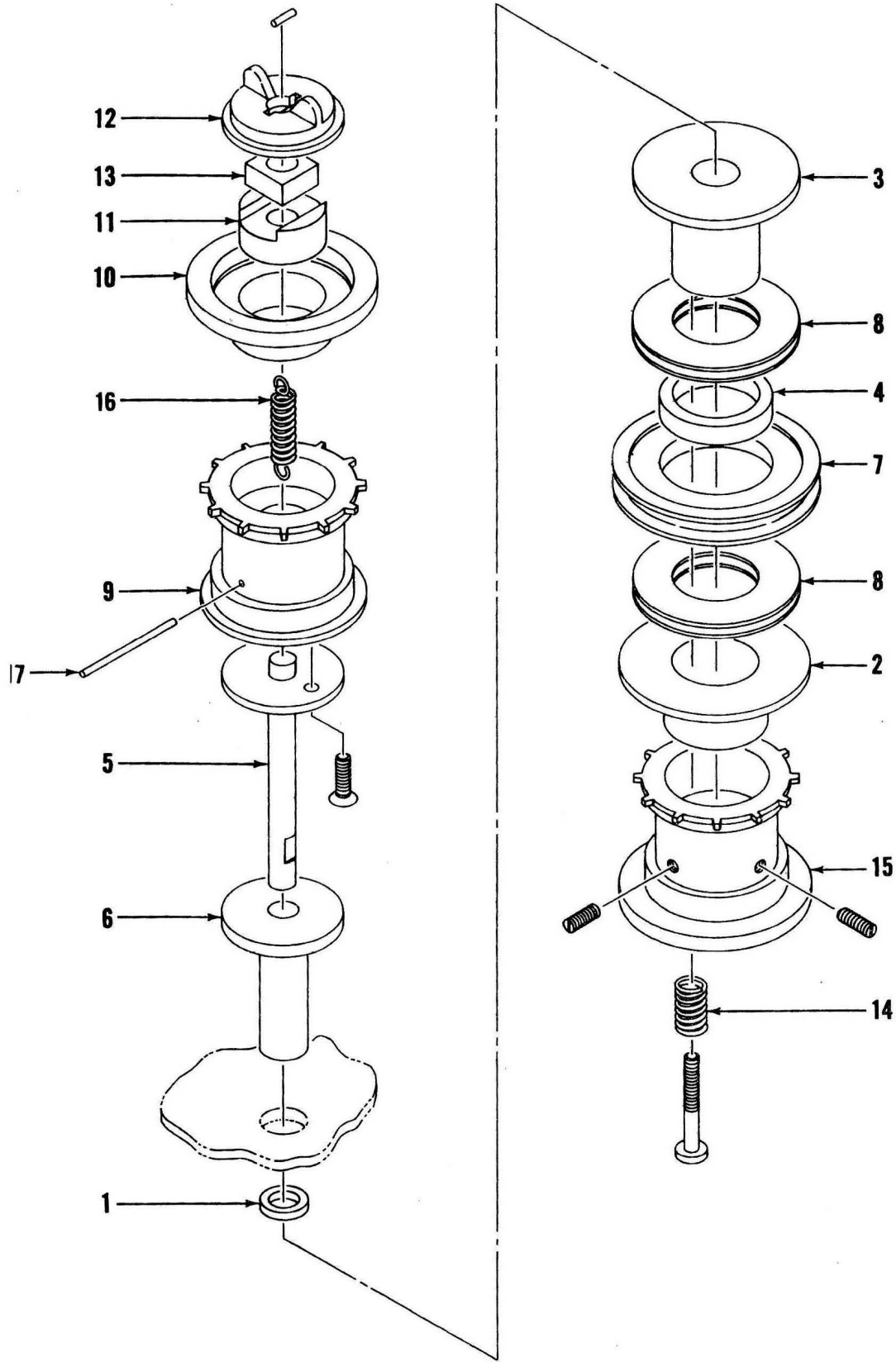

Figure 6-19. Magazine Clutch and Sprocket Assembly

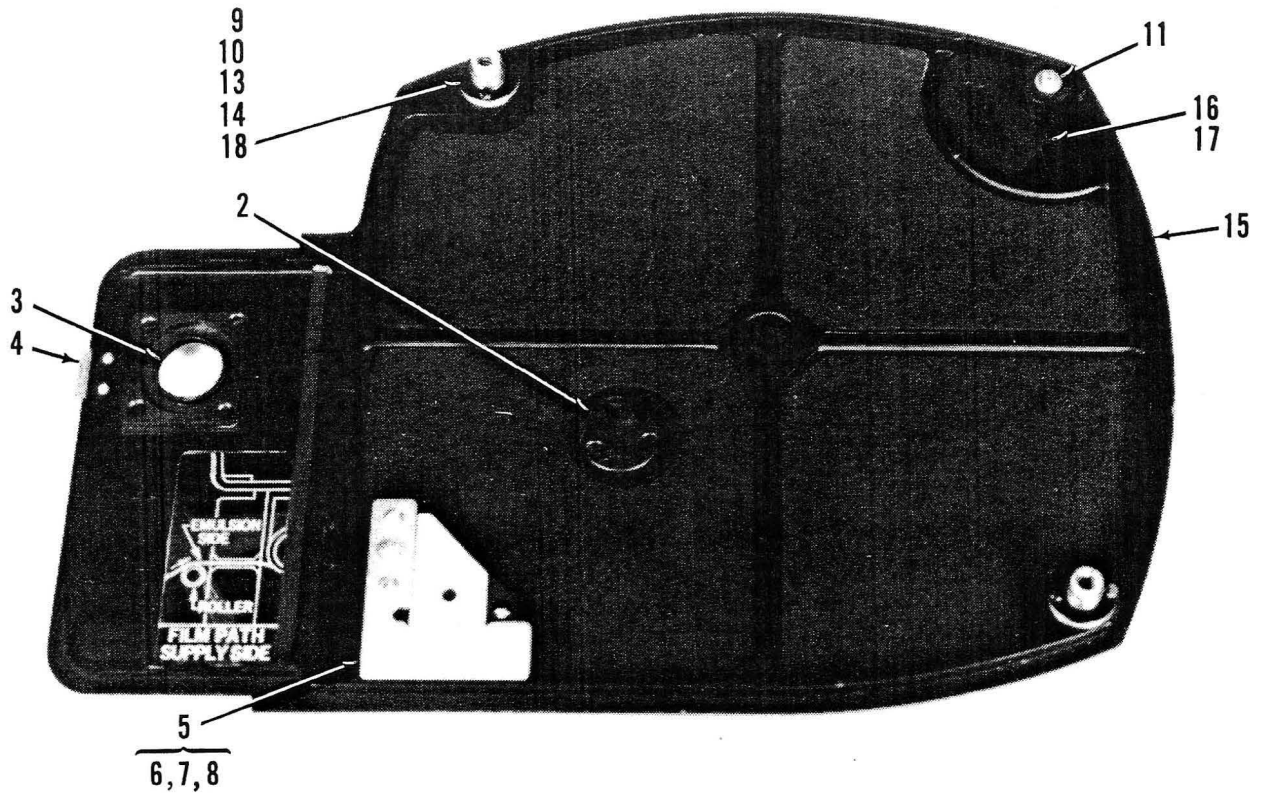

Figure 6-20. Magazine Supply Door Assembly

Fig. & Index No.	Part No.	Description							Units Per Assy	Reference Designation
		1	2	3	4	5	6	7		
6-20-	79-0552-1	DOOR ASSY, Supply (See figure 6-17 for next higher assembly)							REF	
-1		. Not used								
-2	79-0186	. STUD, Holddown							1	
-3	79-0196	. TRAP, Light							1	
-4	79-0198	. PLATE, Rub							1	
-5	79-0199	. FILMCUTTER ASSY							1	
-6	79-0200	. . BASE, Filmcutter							1	
-7	79-0201	. . SHOE, Filmcutter							1	
-8	79-0202	. . BLADE, Filmcutter							1	
-9	79-0211	. RETAINER, Door lock							2	
-10	79-0213	. RECEPTACLE, Dzus							2	
-11	79-0258	. KNOB, Footage counter							1	
-12	79-0546	. PLATE, Write-on (not shown)							1	
-13	79-0547	. SPRING, Door lock							2	
-14	79-0551	. BODY, Door lock							2	
-15	79-0552-2	. DOOR, Supply							1	
-16	79-0557	. FLAG ASSY, Footage counter							1	
-17	79-0569	. SPRING, Footage counter							1	
-18	ORG-134485	. O-RING							2	

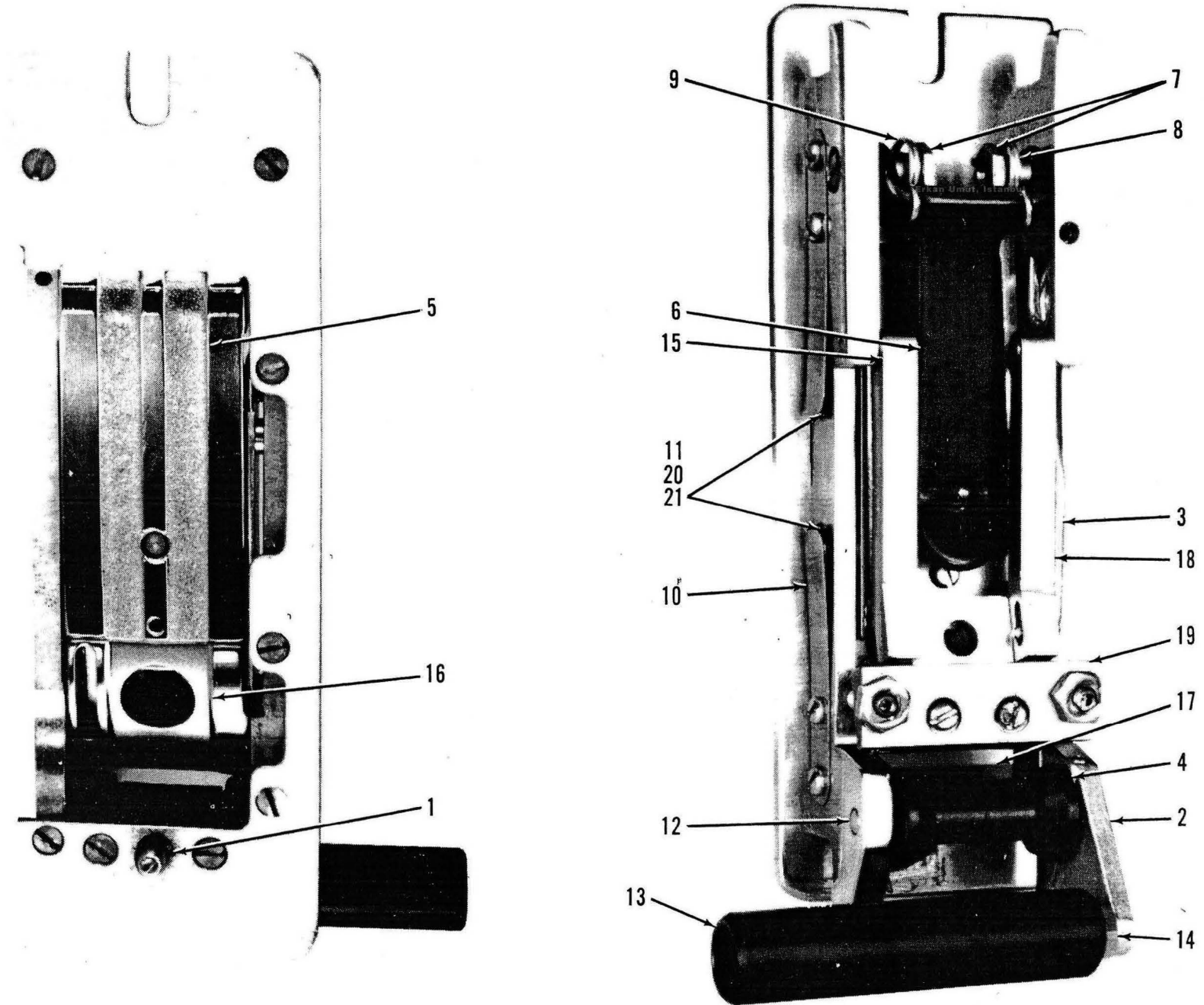

Figure 6-21. Magazine Film Gate Assembly